

Armonya_B

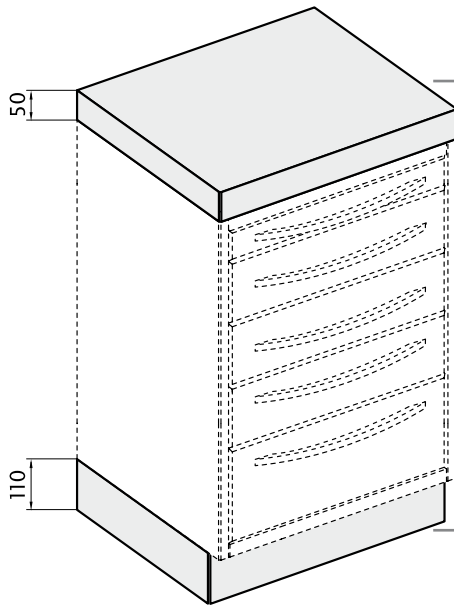

CORNICE H 50 mm fra modulo e piano

FRAME
H 50 mm
between the unit
and the top

CADRE
H 50 mm
entre le module
et le plan

KRANZBLENDE
H 50 mm
zwischen Schrank
und Arbeitsplatte

MARCO
de 50 mm de alto
entre el módulo
y la encimera

BASAMENTO H 110 mm sotto al modulo

BASE UNIT
H 110 mm
under the unit

BASE
H 110 mm
sous le module

SOCKEL
H 110 mm
unter dem Schrank

BASE
de 110 mm de alto
debajo del módulo

Armonya_S

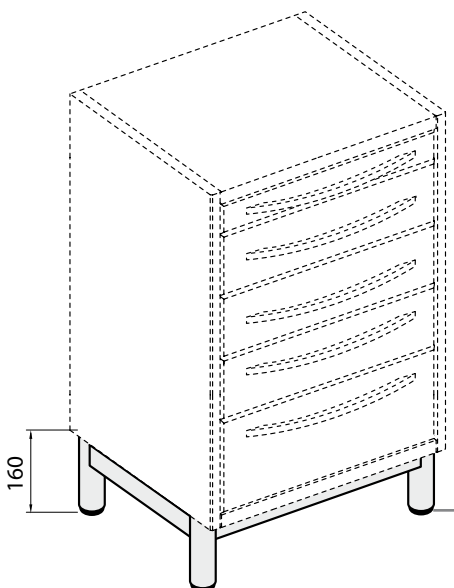

SUPPORTO H 160 mm sotto al modulo

SUPPORT
H 160 mm
under the unit

SUPPORT
H 160 mm
sous le module

GESTELL
H 160 mm
unter dem Schrank

SOPORTE
de 160 mm de alto
debajo del módulo

Armonya_D

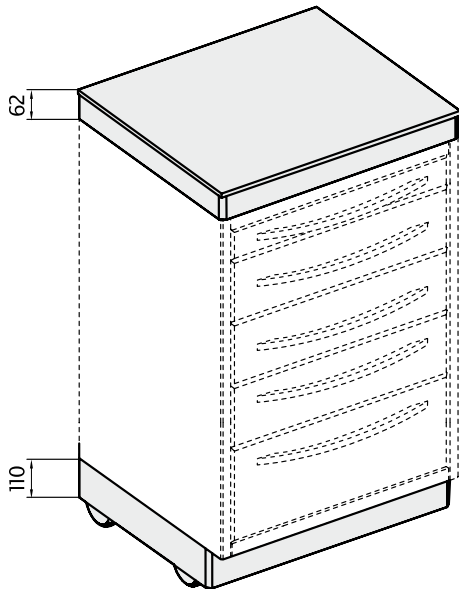

Modulo estraibile montato su RUOTE e alloggiato sotto al piano

Unit on CASTORS hosted under the top

Module monté sur ROUES et logé sous le plan

Aufgestellter Rollenschrank unter der Arbeitsplatte

Módulo montado sobre RUEDAS, alojado debajo de la encimera

Linea Armonya è composta da tre soluzioni indicate con tre sigle distinte: Armonya_B, Armonya_S e Armonya_D.

Armonya_B si caratterizza per il **basamento chiuso** alto 110 mm, posto alla base del modulo, e per la **cornice alta** 50 mm, posta sopra il modulo.

Armonya_S si caratterizza per il **supporto** che rialza il modulo di 160 mm da terra, per permettere una facile e pratica pulizia sotto al mobile.

Armonya_D è la soluzione "dinamica" della linea Armonya. I moduli montati su ruote sono provvisti di una cornice alta 62 mm, completa di pianetto, e vengono alloggiati sotto al piano montato su specifici pannelli di sostegno.

The **Armonya Line** foresees three solutions marked by three different letters: **Armonya_B**, **Armonya_S** and **Armonya_D**.

Armonya_B is characterised by a **closed base unit**, height 110 mm, located at the base of the unit and a **frame** height 50 mm, located on the unit.

Armonya_S is characterised by a **support** that raises the unit 160 mm from the floor, to allow easy and practical cleaning under the furniture.

Armonya_D is the 'dynamic' solution of the Armonya line. The units on castors are provided with a frame, height 62 mm, and a top and are hosted under the worktop mounted on specific support panels.

La **Ligne Armonya** comprend trois solutions, correspondant à trois sigles distincts: **Armonya_B**, **Armonya_S** et **Armonya_D**.

Armonya_B est caractérisée par sa **base fermée**, de 110 mm de hauteur, située à la base du module, ainsi que par son **encadrement** haut de 50 mm, situé sur le module.

Armonya_S est caractérisée par son **support** qui rehausse le module de 160 mm par rapport au sol, pour permettre un nettoyage facile et pratique sous le module.

Armonya_D est la solution "dynamique" de la ligne Armonya. Les modules montés sur roues sont équipés d'un encadrement de 62 mm de hauteur, complet de dessus, et sont logés sous le plan monté sur des panneaux spécifiques de support.

Linea **Armonya** umfasst drei Ausführungen, die drei verschiedene Bezeichnungen haben: **Armonya_B**, **Armonya_S** und **Armonya_D**.

Armonya_B unterscheidet sich durch einen 110 mm hohen **Sockel** unter dem Schrank und eine 50 mm hohe **Kranzblende** über dem Schrank.

Armonya_S unterscheidet sich durch ein **Gestell**, das einen Bodenabstand von 160 mm zum Schrank herstellt, wodurch auch unter dem Schrank die leichte Reinigung möglich ist.

Armonya_D ist die "dynamische" Ausführung der Produktreihe Armonya. Die auf Rollen montierten Schränke haben eine 62 mm hohe Kranzblende mit Auflage und werden unter der Arbeitsplatte aufgestellt, die auf speziellen Stützplatten montiert ist.

Línea Armonya está constituida por tres soluciones indicadas con tres distintas siglas: **Armonya_B**, **Armonya_S** y **Armonya_D**.

Armonya_B se caracteriza por la **base cerrada** de 110 mm de alto, posicionada en la base del módulo, y por el **marco** de 50 mm de alto, posicionado sobre el módulo.

Armonya_S se caracteriza por el **soporte** que sobrealza el módulo de 160 mm del suelo, para permitir una fácil y cómoda limpieza debajo del mueble.

Armonya_D es la solución "dinámica" de la línea Armonya. Los módulos montados sobre ruedas están provistos de un marco de 62 mm de alto, con una encimera y están alojados debajo de la encimera montada sobre unos paneles de soporte específicos.

Armonya

Dimensioni / Dimensions / Dimensions / Maße / Medidas

Loran
everyday passion

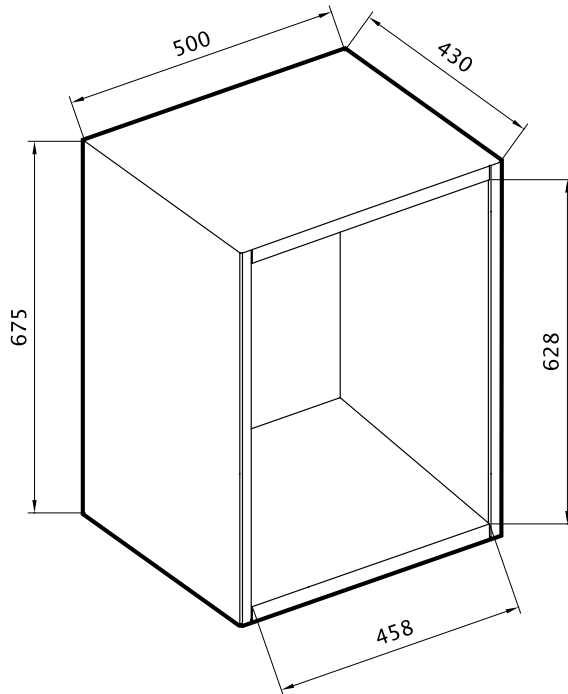

FUSTO

Le misure sono espresse in mm.

STRUCTURE

The dimensions are given in mm.

CORPS

Les mesures sont exprimées en mm.

KORPUS

Die Maße sind in mm angegeben.

MODULO

Las medidas se expresan en mm.

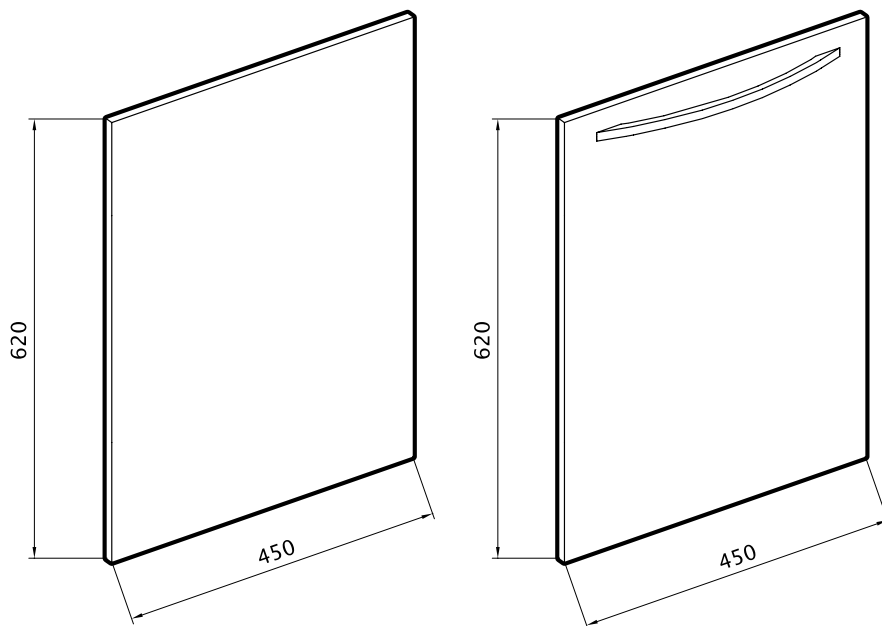

FRONTALI

Le misure sono espresse in mm.

FRONT PANELS

The dimensions are given in mm.

FAÇADES

Les mesures sont exprimées en mm.

FRONTEN

Die Maße sind in mm angegeben.

FRENTES

Las medidas se expresan en mm.

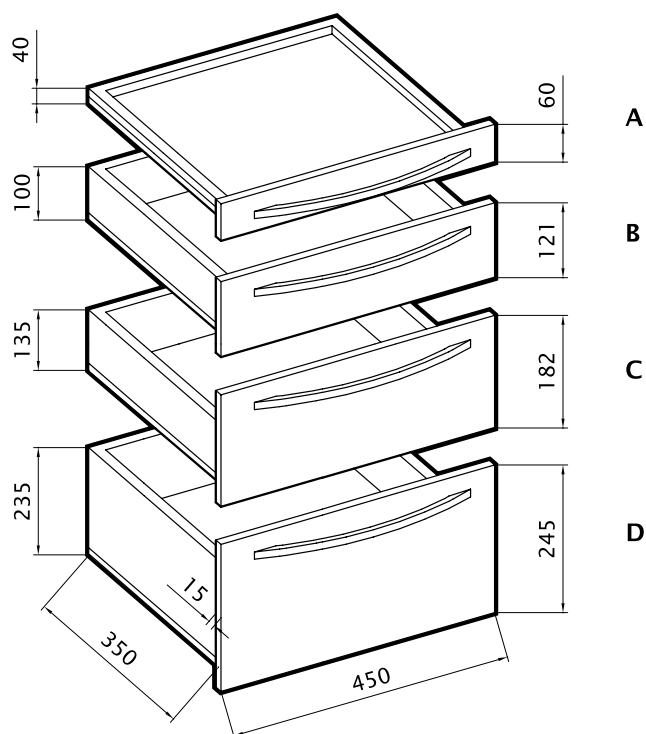

CASSETTI

Le misure sono espresse in mm.

DRAWERS

The dimensions are given in mm.

TIROIRS

Les mesures sont exprimées en mm.

SCHUBLADEN

Die Maße sind in mm angegeben.

CAJONES

Las medidas se expresan en mm.

I cassetti Armonya sono disponibili in 4 differenti altezze. Vengono indicati con le lettere A, B, C e D ed hanno tutti **guide quadro silent system**.

I moduli della linea Armonya vengono già proposti con combinazioni variabili delle diverse tipologie di cassetti, con un occhio sempre attento alla funzionalità d'utilizzo.

The Armonya drawers are available in 4 different heights. They are marked with the letters A, B, C and D and they all have **silent system sliding guides**. The Armonya units are already provided with varying combinations of the different types of drawers to be perfectly functional.

Les tiroirs Armonya sont disponibles dans 4 hauteurs différentes. Ils sont indiqués avec les lettres A, B, C et D et ont tous des **coulisseaux quadro silent system**. Les modules Armonya sont déjà proposés avec des combinaisons variables des différentes typologies de tiroirs, avec un regard toujours attentif à la fonctionnalité d'utilisation.

Die Schubladen Armonya sind in 4 verschiedenen Höhen erhältlich. Sie werden mit den Buchstaben A, B, C und D bezeichnet und haben alle **Quadro-Führungen mit Silent System**. Die Armonya Module werden bereits in unterschiedlichen Kombinationen der verschiedenen Schubkästen angeboten, wobei die Funktionalität immer maßgebend ist.

Los cajones Armonya están disponibles en 4 distintas alturas. Se indican con las letras A, B, C y D y todos están provistos de **guías quadro silent system**. Los módulos de la línea Armonya ya están disponibles con combinaciones variables de los distintos tipos de cajones, con un ojo siempre atento a la funcionalidad de utilización.

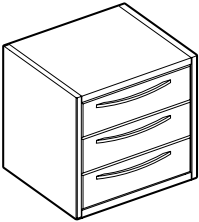
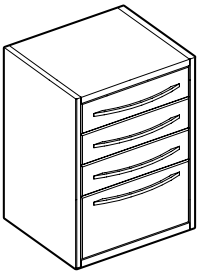
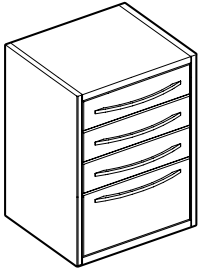
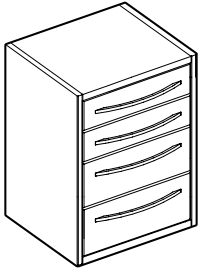
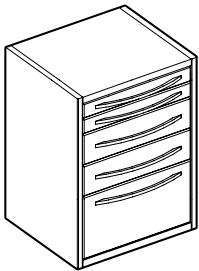
	Descrizione / Description Description / Beschreibung / Descripción	M³ Kg	Articolo Item / Article Artikel / Artículo
	<p>Modulo con 3 cassetti B</p> <p>Unit with 3 drawers B Module avec 3 tiroirs B Schrank mit 3 Schubladen B Módulo con 3 cajones B</p> <p>Bacelle/Trays/Intérieurs de tiroir/Einsätze/Bandejas: 1x9B, 1x10B, 1x11B</p>	0,25 23	AF3_
L 500 x P 430 x H 426 mm			
	<p>Modulo con 3 cassetti B e antina</p> <p>Unit with 3 drawers B and door Module avec 3 tiroirs B et porte Schrank mit 3 Schubladen B und Tür Módulo con 3 cajones B y puerta</p> <p>Bacelle/Trays/Intérieurs de tiroir/Einsätze/Bandejas: 1x9B, 1x10B, 1x11B</p>	0,25 31	AF3P_
L 500 x P 430 x H 675 mm			
	<p>Modulo con 4 cassetti: 3B e 1D</p> <p>Unit with 4 drawers: 3B and 1D Module avec 4 tiroirs: 3B et 1D Schrank mit 4 Schubladen: 3B und 1D Módulo con 4 cajones: 3B y 1D</p> <p>Bacelle/Trays/Intérieurs de tiroir/Einsätze/Bandejas: 1x9B, 1x10B, 1x11B</p>	0,25 34,5	AF3C_
L 500 x P 430 x H 675 mm			
	<p>Modulo con 4 cassetti: 2B e 2C</p> <p>Unit with 4 drawers: 2B and 2C Module avec 4 tiroirs: 2B et 2C Schrank mit 4 Schubladen: 2B und 2C Módulo con 4 cajones: 2B y 2C</p> <p>Bacelle/Trays/Intérieurs de tiroir/Einsätze/Bandejas: 1x9B, 1x10B</p>	0,25 35	AF4
L 500 x P 430 x H 675 mm			
	<p>Modulo con 2 cassetti A, 2B e antina</p> <p>Unit with 2 drawers A, 2B and door Module avec 2 tiroirs A, 2B et porte Schrank mit 2 Schubladen A, 2B und Tür Módulo con 2 cajones A, 2B y puerta</p> <p>Bacelle/Trays/Intérieurs de tiroir/Einsätze/Bandejas: 1x1A, 1x7A, 1x9B, 1x10B</p>	0,25 33,5	AF4P_
L 500 x P 430 x H 675 mm			

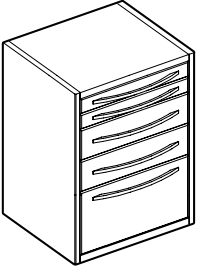
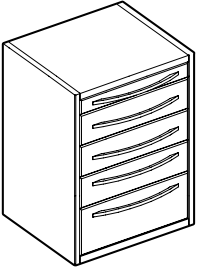
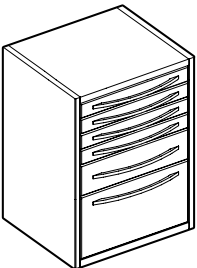
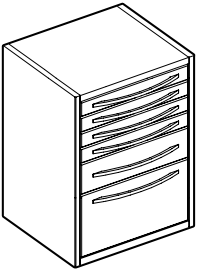
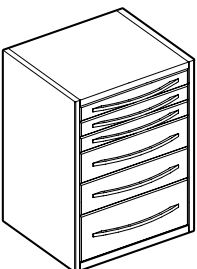
	Descrizione / Description Description / Beschreibung / Descripción	M³ Kg	Articolo Item / Article Artikel / Artículo
	<p>Modulo con 5 cassetti: 2A, 2B e 1 D</p> <p>Unit with 5 drawers: 2A, 2B and 1D Module avec 5 tiroirs: 2A, 2B et 1D Schrank mit 5 Schubladen: 2A, 2B und 1D Módulo con 5 cajones: 2A, 2B y 1D</p> <p>Bacelle/Trays/Intérieurs de tiroir/Einsätze/Bandejas: 1x1A, 1x7A, 1x9B, 1x10B</p>	0,25 37,5	AF4C_
	<p>Modulo con 5 cassetti: 1A, 3B e 1C</p> <p>Unit with 5 drawers: 1A, 3B and 1C Module avec 5 tiroirs: 1A, 3B et 1C Schrank mit 5 Schubladen: 1A, 3B und 1C Módulo con 5 cajones: 1A, 3B y 1C</p> <p>Bacelle/Trays/Intérieurs de tiroir/Einsätze/Bandejas: 1x1A, 1x9B, 1x10B, 1x11B</p>	0,25 38	AF5_
	<p>Modulo con 4 cassetti A, 1B e antina</p> <p>Unit with 4 drawers A, 1B and door Module avec 4 tiroirs A, 1B et porte Schrank mit 4 Schubladen A, 1B und Tür Módulo con 4 cajones A, 1B y puerta</p> <p>Bacelle/Trays/Intérieurs de tiroir/Einsätze/Bandejas: 1x1A, 1x2A, 1x3A, 1x7A, 1x9B</p>	0,25 33,5	AF5P_
	<p>Modulo con 6 cassetti: 4A, 1B e 1D</p> <p>Unit with 6 drawers: 4A, 1B and 1D Module avec 6 tiroirs: 4A,1B et 1D Schrank mit 6 Schubladen: 4A, 1B und 1D Módulo con 6 cajones: 4A, 1B y 1D</p> <p>Bacelle/Trays/Intérieurs de tiroir/Einsätze/Bandejas: 1x1A, 1x2A, 1x3A, 1x7A, 1x9B</p>	0,25 37	AF5C_
	<p>Modulo con 6 cassetti: 3A, 2B e 1C</p> <p>Unit with 6 drawers: 3A, 2B and 1C Module avec 6 tiroirs: 3A, 2B et 1C Schrank mit 6 Schubladen: 3A, 2B und 1C Módulo con 6 cajones: 3A, 2B y 1C</p> <p>Bacelle/Trays/Intérieurs de tiroir/Einsätze/Bandejas: 1x1A, 1x2A, 1x3A, 1x9B, 1x10B</p>	0,25 41	AF6_

L 500 x P 430 x H 675 mm



L 500 x P 430 x H 675 mm

L 500 x P 430 x H 675 mm

L 500 x P 430 x H 675 mm

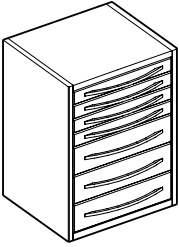
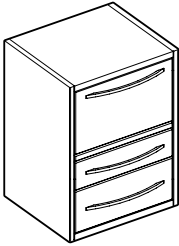
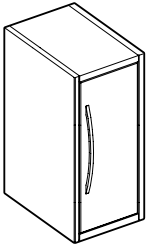
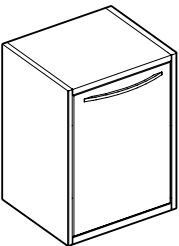
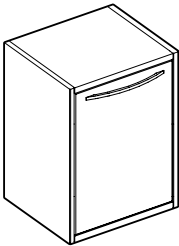
L 500 x P 430 x H 675 mm

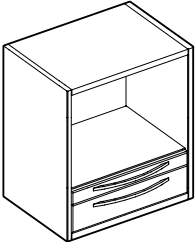
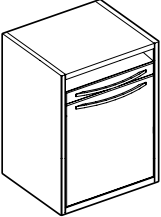
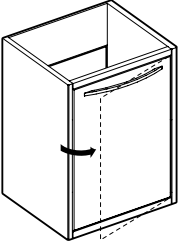
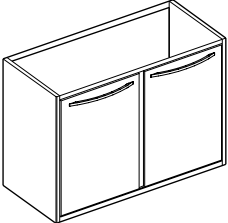
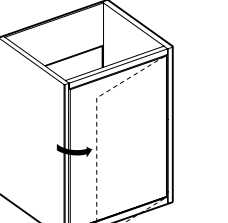
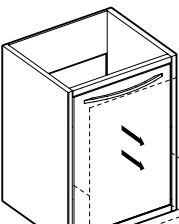
	Descrizione / Description Description / Beschreibung / Descripción	M³ Kg	Articolo Item / Article Artikel / Artículo
	<p>Modulo con 7 cassetti: 4A e 3B</p> <p>Unit with 7 drawers: 4A and 3B Module avec 7 tiroirs: 4A et 3B Schrank mit 7 Schubladen: 4A und 3B Módulo con 7 cajones: 4A y 3B</p> <p>Bacelle/Trays/Intérieurs de tiroir/Einsätze/Bandejas: 1x1A, 1x2A, 1x3A, 1x7A, 1x9B, 1x10B, 1x11B</p>	0,25 44	AF7_
L 500 x P 430 x H 675 mm			
	<p>MODULO con anta a ribalta con 2 ripiani estraibili per apparecchiature + ciabatta con 4 prese di corrente, 1 cassetto B e 1 C</p> <p>Unit with hide-away door equipped with 2 apparatus storage shelves + 4 Schuko sockets, 1 drawer B and 1 C Module avec porte basculante avec 2 tiroirs pour appareils + 4 prises de courant Schuko, 1 tiroir B et 1 C Schrank mit versenkbarer Tür mit 2 Geräteeinlagen + 4 Schuko-Steckdosen, 1 Schublade B und 1 C Módulo con puerta plegable con 2 estantes extraíbles para equipos + regleta con 4 tomas de corriente Schuko, 1 cajón B y 1 C</p> <p>Bacelle/Trays/Intérieurs de tiroir/Einsätze/Bandejas: 1x11B</p>	0,25 31	AF22_
L 500 x P 430 x H 675 mm			
	<p>Modulo con anta e 2 ripiani interni</p> <p>Unit with door and 2 interior shelves Module avec porte et 2 étagères internes Schrank mit Tür und 2 Einlegeböden Módulo con puerta y 2 estantes interiores</p>	0,25 12,5	AFP-3_ (L. 300 mm)
L 300/400 x P 430 x H 675 mm			
	<p>Modulo con anta e 2 ripiani interni</p> <p>Unit with door and 2 interior shelves Module avec porte et 2 étagères internes Schrank mit Tür und 2 Einlegeböden Módulo con puerta y 2 estantes interiores</p>	0,25 21	AFP-5_ (L. 500 mm)
L 500/600 x P 430 x H 675 mm			
	<p>Modulo con frigorifero da incasso (lt. 30)</p> <p>Unit with built-in refrigerator (lt. 30) Module avec réfrigérateur encastrable (lt. 30) Schrank mit Kühlschrank (Lt. 30) Módulo con nevera empotrada (lt. 30)</p>	0,25 34	AFF_
L 500 x P 430 x H 675 mm			

	Descrizione / Description Description / Beschreibung / Descripción	M³ Kg	Articolo Item / Article Artikel / Artículo
	<p>Modulo L 600 per autoclave con 1 cassetto in basso</p> <p>L 600-unit for built-in autoclave, with 1 drawer Module L 600 pour autoclave encastrable, avec 1 tiroir L 600-Schrank zur Integration eines Autoklaven mit 1 Schublade Módulo L 600 para autoclave empotrada con un cajón</p>	0,30 25	AFAU_
	<p>Modulo PC con cassetto A per tastiera da appoggio e anta</p> <p>Unit for PC with 1 drawer A for keyboard and door Module pour PC avec 1 tiroir A pour appuyer le clavier et porte Schrank für PC mit 1 Schublade A für Tastatur und Tür Módulo PC con 1 cajón A para teclado y puerta</p>	0,25 23	AFPC_
	<p>MODULO sottolavello con anta e portarifiuti interno</p> <p>Sink unit with door and rubbish bin Module lavabo avec porte et poubelle Waschbeckenschrank mit Tür und Abfalleimer Módulo lavabo con puerta y cubo de basura</p>	0,25 18	AL-I_ (L. 500 mm)
	<p>MODULO sottolavello con 2 ante e portarifiuti interno</p> <p>Sink unit with 2 doors and rubbish bin Module lavabo avec 2 portes et poubelle Waschbeckenschrank mit 2 Türen und Abfalleimer Módulo lavabo con 2 puertas y cubo de basura</p>	0,30 20	AL-I1_ (L. 600 mm)
	<p>MODULO sottolavello con 2 ante e portarifiuti interno</p> <p>Sink unit with 2 doors and rubbish bin Module lavabo avec 2 portes et poubelle Waschbeckenschrank mit 2 Türen und Abfalleimer Módulo lavabo con 2 puertas y cubo de basura</p>	0,55 27	AL-I2_
	<p>Modulo sottolavello con anta apertura laterale a "ginocchio" e portarifiuti interno</p> <p>Sink unit with knee-opening door and rubbish bin Module lavabo avec porte avec ouverture à genou et poubelle Waschbeckenschrank mit Tür mit Knieöffnung und Abfalleimer Módulo lavabo con puerta con apertura de codillo y cubo de basura</p>	0,25 18	AL-G_
	<p>Modulo sottolavello con cassettone estraibile e cestello portarifiuti interno</p> <p>Sink unit with pull-out door and rubbish bin Module lavabo avec porte extractible et poubelle Waschbeckenschrank mit ausziehbarer Tür und Abfalleimer Módulo lavabo con puerta extraible y cubo de basura</p>	0,25 21	AL-C_

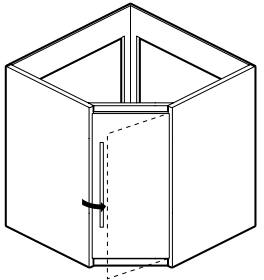
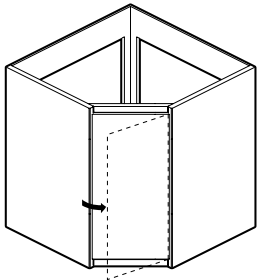
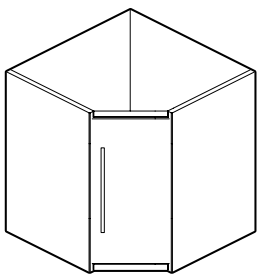
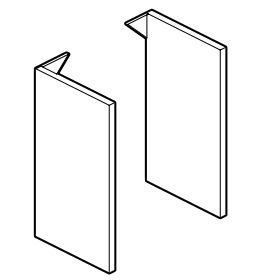
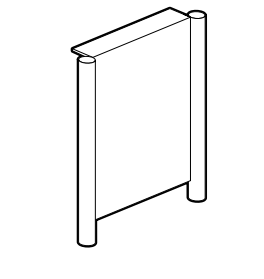
	Descrizione / Description Description / Beschreibung / Descripción	M³ Kg	Articolo Item / Article Artikel / Artículo
 <p>L 645 x P 645x H 675 mm</p>	<p>MODULO angolare sottolavello con anta e portarifiuti interno</p> <p>Corner sink unit with door and rubbish bin Module lavabo d'angle avec porte et poubelle Eckwaschbeckenschrank mit Tür und Abfalleimer Módulo angular lavabo con puerta y cubo de basura</p>	<p>0,50 ----- 20</p>	<p>ALA-I_</p>
 <p>L 645 x P 645x H 675 mm</p>	<p>Modulo angolare sottolavello con anta apertura laterale a "ginocchio" e portarifiuti interno</p> <p>Corner sink unit with knee-opening door and rubbish bin Module lavabo d'angle avec porte avec ouverture à genou et poubelle Eckwaschbeckenschrank mit Tür mit Knieöffnung und Abfalleimer Módulo lavabo angular con puerta con apertura de codillo y cubo de basura</p>	<p>0,50 ----- 20</p>	<p>ALA-G_</p>
 <p>L 645 x P 645x H 675 mm</p>	<p>Modulo angolare con anta e 1 ripiano interno</p> <p>Corner unit with door and 1 interior shelf Module d'angle avec porte et 1 étagère interne Eckschrank mit Tür und 1 Einlegeboden Módulo angular con puerta y 1 estante interior</p>	<p>0,50 ----- 21,5</p>	<p>AFA_</p>
 <p>L 25 x P 430 x H 835 mm</p>	<p>Pannello laterale sx o dx di sostegno piano</p> <p>Left or right top-support side panel Panneau latéral, gauche ou droit, de support pour le plan Abschlußverkleidung (links oder rechts) Panel lateral, izquierdo o derecho, para el soporte de la encimera</p>	<p>- ----- 6</p>	<p>SLS/SLD</p>
 <p>L 40 x P 430 x H 835 mm</p>	<p>Pannello laterale in tubolare di sostegno piano</p> <p>Top-support side panel Panneau latéral en tubulaire, de support pour le plan Abschlußverkleidung aus Profilrohr Panel lateral en tubular, para el soporte de la encimera</p>	<p>- ----- 6</p>	<p>SLT</p>

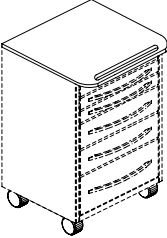
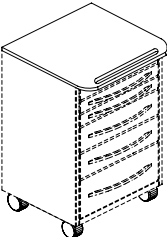
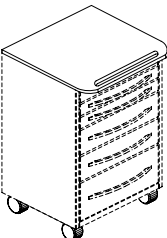
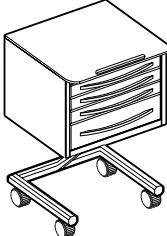
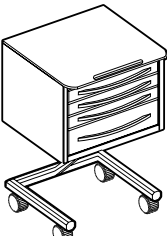
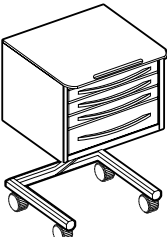
	Descrizione / Description Description / Beschreibung / Descripción	M³ Kg	Articolo Item / Article Artikel / Artículo
	<p>Kit ruote + piano sagomato in vetro Castor set + shaped glass top Kit roues + plan façonné en verre Rollenset + geformte Glasarbeitsplatte Kit de ruedas + encimera perfilada de vidrio</p>	<p>0,05 ----- 10,1</p>	KRV
L 502 x P 502 x H 103 mm		<p>Extra-chiaro / Extra clear / Transparent Transparent / Extra-claro Satinato / Satin / Dépoli Satiniert / Satinado</p>	
	<p>Kit ruote + piano sagomato in Corian® bianco Castor set + shaped white Corian® top Kit roues + plan façonné en Corian® blanc Rollenset + geformte Arbeitsplatte aus weißem Corian® Kit de ruedas + encimera perfilada de Corian® blanco</p>	<p>0,05 ----- 6,3</p>	KRC
L 502 x P 509 x H 100 mm			
	<p>Kit ruote + piano sagomato in stratificato bianco Castor set + shaped white stratified top Kit roues + plan façonné en stratifié blanc Rollenset + geformte Arbeitsplatte aus weißem Schichtstoff Kit de ruedas + encimera perfilada de estratificado blanco</p>	<p>0,05 ----- 5,6</p>	KRS
L 502 x P 509 x H 100 mm			
	<p>Modulo su carrello con 4 cassetti: 3A e 1B. Piano sagomato in vetro Movable unit with 4 drawers: 3A and 1B. Shaped glass top Module mobile avec 4 tiroirs: 3A et 1B. Plan façonné en verre Rollenschränk mit 4 Schubladen: 3A und 1B. Geformte Glasarbeitsplatte Elemento móvil con 4 cajones: 3A y 1B. Encimera perfilada de vidrio</p>	<p>0,30 ----- 40,5</p>	AC4-V
L 502 x P 502 x H 765 mm		<p>Extra-chiaro / Extra clear / Transparent Transparent / Extra-claro Satinato / Satin / Dépoli Satiniert / Satinado</p>	
	<p>Modulo su carrello con 4 cassetti: 3A e 1B. Piano sagomato in Corian® bianco Movable unit with 4 drawers: 3A and 1B. Shaped white Corian® top Module mobile avec 4 tiroirs: 3A et 1B. Plan façonné en Corian® blanc Rollenschränk mit 4 Schubladen: 3A und 1B. Geformte Arbeitsplatte aus weißem Corian® Elemento móvil con 4 cajones: 3A y 1B. Encimera perfilada de Corian® blanco</p>	<p>0,30 ----- 36,7</p>	AC4-C
L 502 x P 509 x H 762 mm			
	<p>Modulo su carrello con 4 cassetti: 3A e 1B. Piano sagomato in stratificato bianco Movable unit with 4 drawers: 3A and 1B. Shaped white stratified top Module mobile avec 4 tiroirs: 3A et 1B. Plan façonné en stratifié blanc Rollenschränk mit 4 Schubladen: 3A und 1B. Geformte Arbeitsplatte aus weißem Schichtstoff Elemento móvil con 4 cajones: 3A y 1B. Encimera perfilada de estratificado blanco</p>	<p>0,30 ----- 36</p>	AC4-S
L 502 x P 509 x H 762 mm			

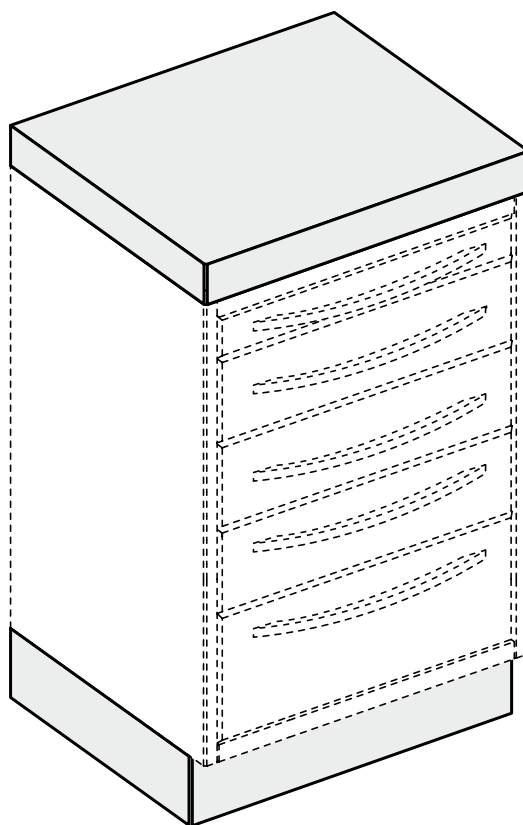

Dimensioni Dimensions / Dimensions Maße / Medidas	Descrizione / Description Description / Beschreibung / Descripción	M³ Kg	Articolo Item / Article Artikel / Artículo
L 635 x P 635 x H 50 mm L 605 x P 605 x H 110 mm	Cornice e basamento angolare Corner frame and base unit - Cadre et base d'angle Eckkranzblende und Ecksockel - Marco y base angular	- 5,5	CB01
L 300 x P 420 x H 50 mm L 300 x P 390 x H 110 mm	Cornice e basamento L 300 Frame and base unit L 300 - Cadre et base L 300 Kranzblende und Sockel L 300 - Marco y base L 300	- 2,5	CB02
L 400 x P 420 x H 50 mm L 400 x P 390 x H 110 mm	Cornice e basamento L 400 Frame and base unit L 400 - Cadre et base L 400 Kranzblende und Sockel L 400 - Marco y base L 400	- 3,5	CB06
L 500 x P 420 x H 50 mm L 500 x P 390 x H 110 mm	Cornice e basamento L 500 Frame and base unit L 500 - Cadre et base L 500 Kranzblende und Sockel L 500 - Marco y base L 500	- 4	CB03
L 600 x P 420 x H 50 mm L 600 x P 390 x H 110 mm	Cornice e basamento L 600 Frame and base unit L 600 - Cadre et base L 600 Kranzblende und Sockel L 600 - Marco y base L 600	- 5	CB04
L 1000 x P 420 x H 50 mm L 1000 x P 390 x H 110 mm	Cornice e basamento L 1000 Frame and base unit L 1000 - Cadre et base L 1000 Kranzblende und Sockel L 1000 - Marco y base L 1000	- 6	CB05

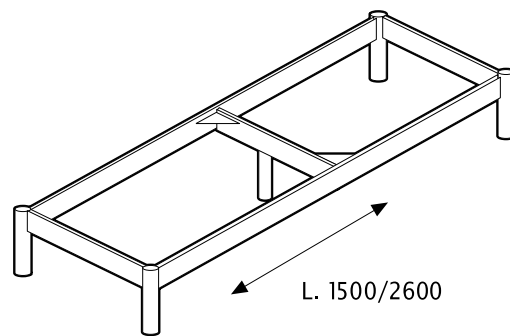
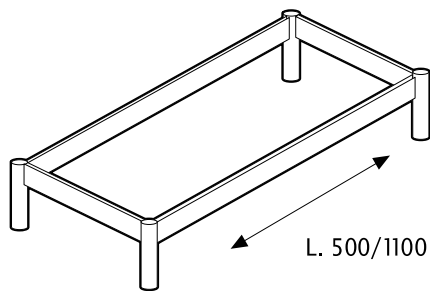

Dimensioni Dimensions / Dimensions Maße / Medidas	Descrizione / Description Description / Beschreibung / Descripción	M ³ Kg	Articolo Item / Article Artikel / Artículo
L 635 x P 635 x H 160 mm	Supporto angolare con piedini Corner support with feet - Support d'angle avec pieds Eckgestell mit Füßen - Soporte angular con patas	0,10 5	SR01
L 500 x P 390 x H 160 mm	Supporto L 500 con piedini Support with feet L 500 - Support L 500 avec pieds Gestell L 500 mit Füßen - Soporte con patas L 500	0,05 4	SR05
L 600 x P 390 x H 160 mm	Supporto L 600 con piedini Support with feet L 600 - Support L 600 avec pieds Gestell L 600 mit Füßen - Soporte con patas L 600	0,05 4,5	SR06
L 1000 x P 390 x H 160 mm	Supporto L 1000 con piedini Support with feet L 1000 - Support L 1000 avec pieds Gestell L 1000 mit Füßen - Soporte con patas L 1000	0,10 5	SR10
L 1100 x P 390 x H 160 mm	Supporto L 1100 con piedini Support with feet L 1100 - Support L 1100 avec pieds Gestell L 1100 mit Füßen - Soporte con patas L 1100	0,10 5,5	SR11
L 1500 x P 390 x H 160 mm	Supporto L 1500 con piedini Support with feet L 1500 - Support L 1500 avec pieds Gestell L 1500 mit Füßen - Soporte con patas L 1500	0,12 8	SR15
L 1600 x P 390 x H 160 mm	Supporto L 1600 con piedini Support with feet L 1600 - Support L 1600 avec pieds Gestell L 1600 mit Füßen - Soporte con patas L 1600	0,12 8,5	SR16
L 2000 x P 390 x H 160 mm	Supporto L 2000 con piedini Support with feet L 2000 - Support L 2000 avec pieds Gestell L 2000 mit Füßen - Soporte con patas L 2000	0,16 10	SR20
L 2100 x P 390 x H 160 mm	Supporto L 2100 con piedini Support with feet L 2100 - Support L 2100 avec pieds Gestell L 2100 mit Füßen - Soporte con patas L 2100	0,16 10,5	SR21
L 2500 x P 390 x H 160 mm	Supporto L 2500 con piedini Support with feet L 2500 - Support L 2500 avec pieds Gestell L 2500 mit Füßen - Soporte con patas L 2500	0,20 12,5	SR25
L 2600 x P 390 x H 160 mm	Supporto L 2600 con piedini Support with feet L 2600 - Support L 2600 avec pieds Gestell L 2600 mit Füßen - Soporte con patas L 2600	0,20 13	SR26

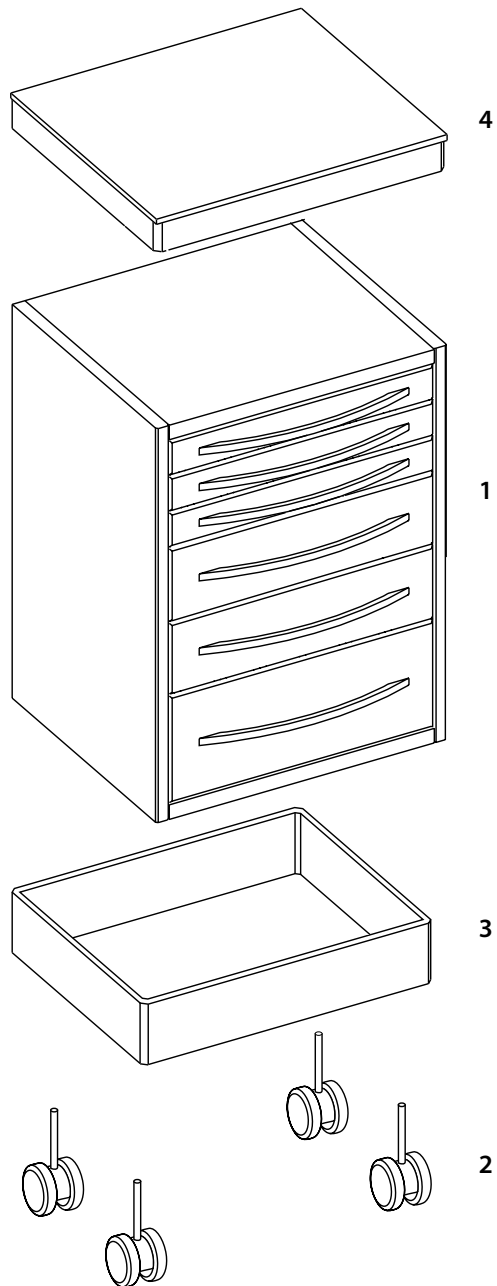

Armonya_D: la soluzione “dinamica” della linea Armonya.

I moduli della linea Armonya_D si compongono di un modulo a scelta (1), montato su ruote (2) opportunamente nascoste da uno zoccolo (3), e sono provvisti di una cornice alta 62 mm **completa di pianetto (4)**.

Il modulo così composto viene alloggiato sotto al piano e bloccato posteriormente da placche magnetiche che ne danno la perfetta stabilità.

Armonya_D: the “dynamic” solution of the Armonya line. The units of the Armonya_D line consist of a unit (1) that is mounted on castors (2) hidden behind a plinth (3) and come with a 62 mm high frame **complete with a top (4)**. The unit is housed under the top and is secured at the back by magnetic plates which provide added stability.

Armonya_D: la solution “dynamique” de la ligne Armonya. Les modules de la ligne Armonya_D se composent d’un module au choix (1), monté sur des roues (2) opportunément cachées par un socle (3); ils sont équipés d’une corniche de 62 mm de haut, **complète de dessus (4)**. Le module ainsi composé est logé sous le plan et est bloqué à l’arrière au moyen de plaques magnétiques qui garantissent sa parfaite stabilité.

Armonya_D: die “dynamische” Lösung der Linie Armonya. Die Schränke der Linie Armonya_D bestehen aus einem Schrank (1) nach Wahl, das auf Rollen (2) montiert ist, die hinter einem Sockel (3) verborgen sind, und haben eine 62 mm hohe Kranzblende **komplett mit Auflage (4)**. Das so entstandene Schrank wird unter der Arbeitsplatte aufgestellt und auf der Rückseite mit Magnetplatten befestigt, die absolute Stabilität gewährleisten.

Armonya_D: la solución “dinámica” de la línea Armonya. Los módulos de la línea Armonya_D están constituidos por un elemento modular a elección (1), montado sobre ruedas (2) oportunamente ocultas por un zócalo (3), y están provistos de un marco de 62 mm de alto **con encimera (4)**. El módulo así formado se aloja debajo de la encimera y se fija en la parte posterior con unas placas magnéticas que le dan una estabilidad perfecta.

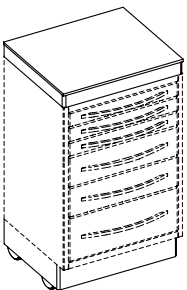
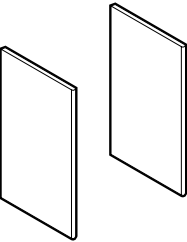
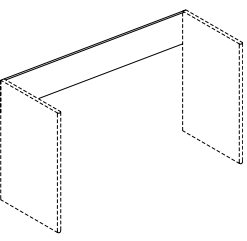
	Descrizione / Description Description / Beschreibung / Descripción	M³ Kg	Articolo Item / Article Artikel / Artículo
 <p data-bbox="132 645 363 696"> L 500 x P 420 x H 62 mm L 500 x P 390 x H 110 mm </p>	<p data-bbox="411 432 911 461">Cornice con pianetto + basamento con kit ruote</p> <p data-bbox="411 468 823 497">Frame with top + base unit with castor set</p> <p data-bbox="411 504 775 533">Cadre avec plan + base avec kit roues</p> <p data-bbox="411 539 852 568">Kranzblende mit Platte + Sockel mit Rollenset</p> <p data-bbox="411 575 852 604">Marco con encimera + base con kit de ruedas</p>	<p data-bbox="1114 645 1145 696">-</p> <p data-bbox="1114 674 1145 696">6</p>	<p data-bbox="1310 663 1366 696">KRD</p>
 <p data-bbox="132 1084 352 1113">L 25 x P 430 x H 855 mm</p>	<p data-bbox="411 817 855 846">Pannello laterale sx o dx di sostegno piano</p> <p data-bbox="411 853 751 882">Left or right top-support side panel</p> <p data-bbox="411 889 842 949">Panneau latéral, gauche ou droit, de support pour le plan</p> <p data-bbox="411 956 794 985">Abschlußverkleidung (links oder rechts)</p> <p data-bbox="411 992 887 1052">Panel lateral, izquierdo o derecho, para el soporte de la encimera</p>	<p data-bbox="1114 1055 1145 1106">-</p> <p data-bbox="1114 1084 1145 1106">5</p>	<p data-bbox="1278 1077 1398 1111">DLS/DLD</p>
 <p data-bbox="132 1498 228 1527">H 205 mm</p>	<p data-bbox="411 1267 1007 1296">Pannello posteriore per box Armonya_D: al metro lineare</p> <p data-bbox="411 1303 815 1332">Back panel for box Armonya_D: per meter</p> <p data-bbox="411 1339 874 1368">Panneau arrière pour box Armonya_D: au mètre</p> <p data-bbox="411 1375 815 1404">Hinterplatte für Box Armonya_D: je Meter</p> <p data-bbox="411 1411 826 1440">Panel trasero para el box Armonya_D: al m.</p>	<p data-bbox="1114 1469 1145 1520">-</p> <p data-bbox="1114 1503 1145 1525">3,5</p>	<p data-bbox="1310 1491 1366 1525">PPA</p>

Composizione Lineare nelle soluzioni _B/ _S/ _D

Straight composition in the solutions _B/ _S/ _D

Composition linéaire dans les solutions _B/ _S/ _D

Lineare Zusammenstellung in den Ausführungen _B/ _S/ _D

Composición lineal en las soluciones _B/ _S/ _D

Armonya_B

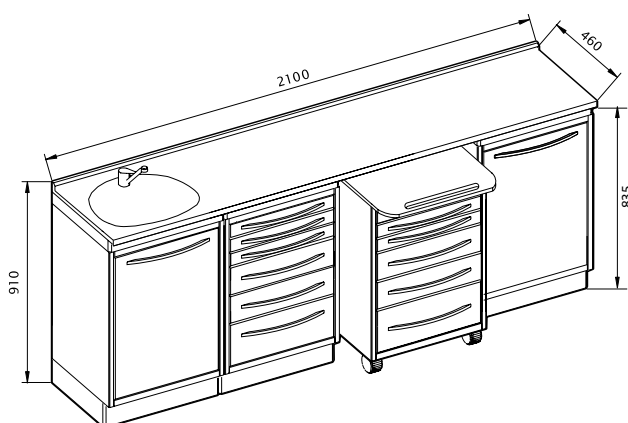

AL-I_B+KEL+AF6_B+AF6+KR...+AFP-5_B+3 CB03+TOP...+V...+RB...

Armonya_S

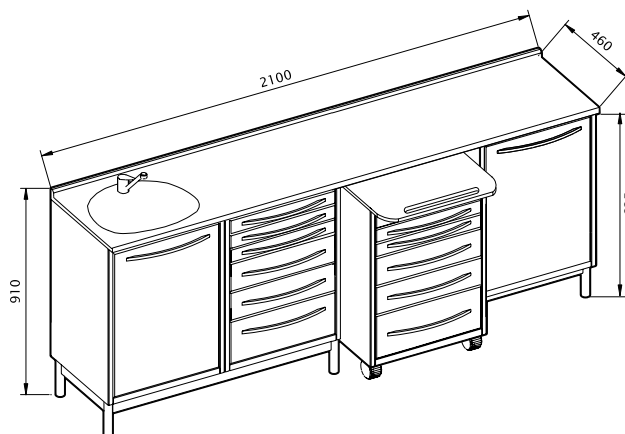

AL-I_S+KEL+AF6_S+AF6+KR...+AFP-5_S+SR10+SR05+TOP...+V...+RB...

Armonya_D

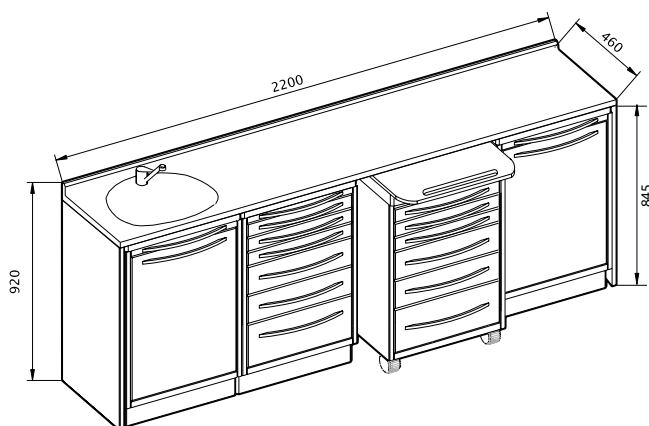

AL-I_D+KEL+AF6_D+AF6+KR...+AFP-5_D+3 KRD+DLS+DLD+PPA+TOP...+V...+RB...

Armonya

- | | |
|---------------------------------------|-------------------|
| Piano laminato | VCF+RB2 |
| Laminated top | |
| Plan en laminé | KRV |
| Laminatarbeitsplatte | KRC |
| Encimera de laminado | |
| Piano stratificato bianco | VAS+RB3 |
| White stratified top | |
| Plan en stratifié blanc | |
| Arbeitsplatte aus weißem | |
| Schichtstoff | KRS |
| Encimera de estratificado blanco | |
| L 2100 x P 505 x H 847 mm | |
| Piano vetro sp.15mm | VVI/15+RB2 |
| colori standard | |
| Glass top th. 15mm - standard colors | |
| Plan en verre ép. 15mm - couleurs | |
| standard | |
| Glasarbeitsplatte St. 15mm - Standard | |
| Farben | |
| Encimera de vidrio es. 15mm | |
| colores estándar | KRV |
| L 2100 x P 505 x H 850 mm | |

Composizione Angolare nelle soluzioni _B / _S / _D

Corner composition in the solutions _B / _S / _D
 Composition d'angle dans les solutions _B / _S / _D
 Eckzusammenstellung in den Ausführungen _B / _S / _D
 Composición angular en las soluciones _B / _S / _D

Armonya_B

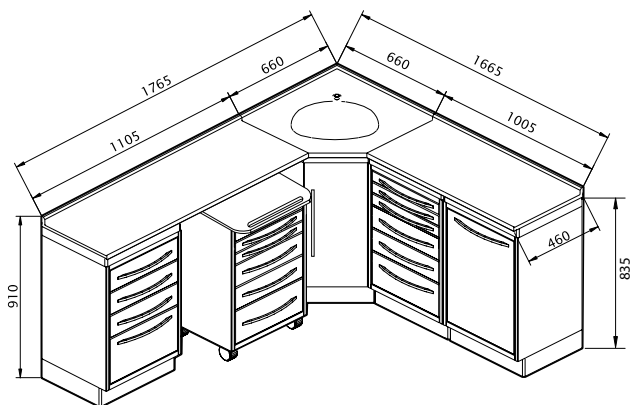

AF3C_B+AF6+KR...+ALA-I_B+KEL+AF6_B+AFP-5_B+CB01+3 CB03+TOP...+V...+RB...

Armonya_S

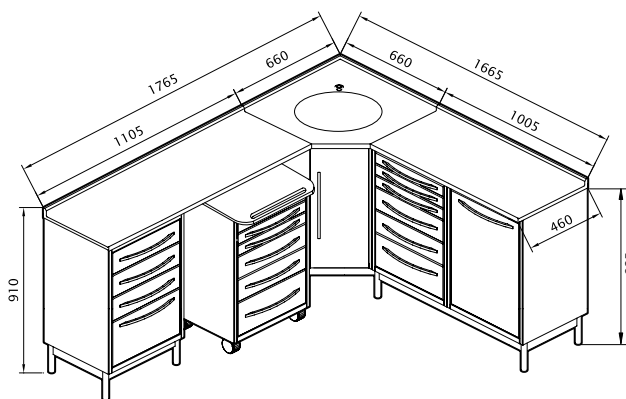

AF3C_S+AF6 + KR...+ALA-I_S+KEL+AF6_S+AFP-5_S+SR05+SR01+SR10+TOP...+V...+RB...

Armonya_D

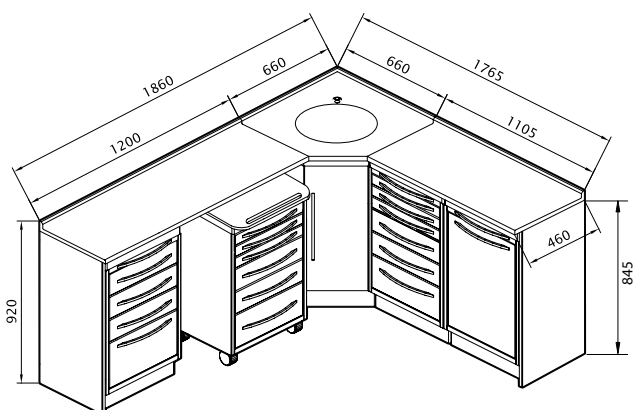

AF3C_D+AF6+KR...+ALA-I_D+KEL+AF6_D+AFP-5_D+3 KR D+CB01+
 DLS+DL D+PPA+TOP...+V...+RB...

Armonya

Piano laminato VCF+RB2

Laminated top
 Plan en laminé
 Laminatarbeitsplatte
 Encimera de laminado

KRV
 KRC

Piano stratificato bianco VAS+RB3

Whiote stratified top
 Plan en stratifié blanc
 Arbeitsplatte aus weißem
 Schichtstoff
 Encimera de estratificado blanco

KRS

L 1810 x 1710 x P 505 x H 847 mm

**Piano vetro sp.15mm VIT+RB2
 colori standard**

Glass top th. 15mm - standard colors
 Plan en verre ép. 15mm - couleurs
 standard
 Glasarbeitsplatte St. 15mm - Standard
 Farben
 Encimera de vidrio es. 15mm
 colores estándar

KRV

L 1810 x 1710 x P 505 x H 850 mm

Vela - Armonya - Start

Piani / Tops / Plans / Arbeitsplatten / Encimeras

Loran
everyday passion

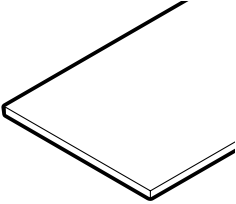
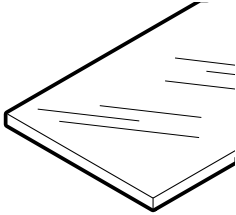
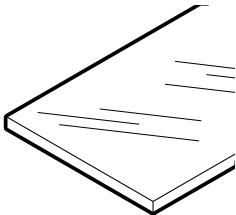
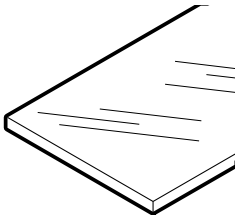
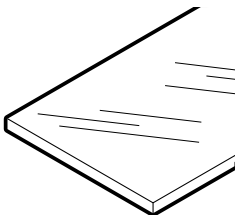
	Descrizione / Description Description / Beschreibung / Descripción	M³ Kg	Articolo Item / Article Artikel / Artículo
 <p>Piano in Corian® bianco: al metro lineare White Corian® top: per meter Plan en Corian® blanc: au mètre Weiß Corian® Arbeitsplatte: je Meter Encimera de Corian® blanco: al m.</p>		- 11	CB (P 505 mm)
	<p>P 505 x H 12 mm P 600 x H 12 mm</p>		- 13
 <p>Piano in vetro: al metro lineare Glass top: per meter Plan en verre: au mètre Glasarbeitsplatte: je Meter Encimera de vidrio: al m.</p>		- 19	VB
<p>P 505 x H 15 mm</p>			
 <p>Piano in vetro satinato: al metro lineare Glass top satin: per meter Plan en verre dépoli: au mètre Satinierte Glasarbeitsplatte: je Meter Encimera de vidrio satinado: al m.</p>		- 19	XB
<p>P 505 x H 15 mm</p>			
 <p>Piano in vetro extra-chiaro: al metro lineare Extra clear glass top: per meter Plan en verre transparent: au mètre Transparente Glasarbeitsplatte: je Meter Encimera de vidrio transparente: al m.</p>		- 19	YB
<p>P 505 x H 15 mm</p>			
 <p>Piano in vetro extra-chiaro satinato: al metro lineare Extra-clear glass top satin: per meter Plan en verre transparent dépoli: au mètre Transparente satinierte Glasarbeitsplatte: je Meter Encimera de vidrio transparente satinado: al m.</p>		- 19	ZB
<p>P 505 x H 15 mm</p>			

Vela - Armonya - Start

Piani / Tops / Plans / Arbeitsplatten / Encimeras

Loran
everyday passion

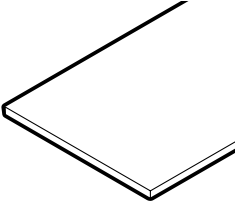
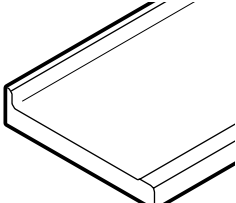
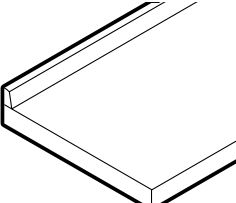
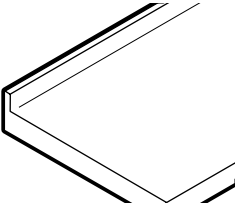
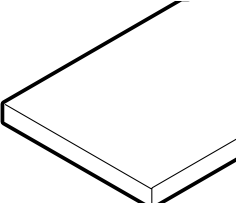
	Descrizione / Description Description / Beschreibung / Descripción	M³ Kg	Articolo Item / Article Artikel / Artículo
 <p>Piano in stratificato bianco: al metro lineare White stratified top: per meter Plan en stratifié blanc: au mètre Weiß Schichtstoffarbeitsplatte: je Meter Encimera de estratificado blanco: al m.</p> <p>P 505 x H 12 mm P 600 x H 12 mm</p>		- 9,6	SB (P 505 mm)
		- 11,4	SD (P 600 mm)
 <p>Piano in laminato con alzatina incorporata H 45 mm: al metro lineare Laminated top with rear trim H 45 mm: per meter Plan en laminé avec dossier H 45 mm: au mètre Laminatarbeitsplatte mit Aufkantung H 45 mm: je Meter Encimera de laminado con elevación H 45 mm: al m.</p> <p>P 460 x H 30 mm P 520 x H 30 mm</p>		- 10	BA (P 460 mm)
		- 11	BC (P 520 mm)
 <p>Piano in laminato con alzatina applicata ALB H 40 mm: al metro lineare Laminated top with applied rear trim ALB H 40 mm: per meter Plan en laminé avec dossier appliqué ALB H 40 mm: au mètre Laminatarbeitsplatte mit aufgeklebter Aufkantung ALB H 40 mm: je Meter Encimera de laminado con elevación aplicado ALB H 40 mm: al m.</p> <p>P 460 x H 30 mm P 520 x H 30 mm P 600 x H 30 mm</p>		- 10	TA (P 460 mm)
		- 11	TC (P 520 mm)
		- 12	TD (P 600 mm)
 <p>Piano in acciaio inox con alzatina incorporata H 70 mm: al metro lineare Stainless steel top with rear trim H 70 mm: per meter Plan en acier inox avec dossier H 70 mm: au mètre Edelstahlarbeitsplatte mit Aufkantung H 70 mm: je Meter Encimera de acero inox con elevación H 70 mm: al m.</p> <p>P 520 x H 30 mm P 600 x H 30 mm</p>		- 14	HC (P 520 mm)
		- 18	HD (P 600 mm)
 <p>Piano in acciaio inox senza alzatina: al metro lineare Stainless steel top: per meter Plan en acier inox : au mètre Edelstahlarbeitsplatte: je Meter Encimera de acero inox: al m.</p> <p>P 520 x H 30 mm P 600 x H 30 mm</p>		- 13	IC (P 520 mm)
		- 15	ID (P 600 mm)

Armonya - Start

Piani / Tops / Plans / Arbeitsplatten / Encimeras

Loran
everyday passion

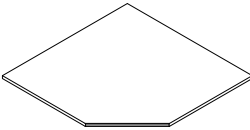
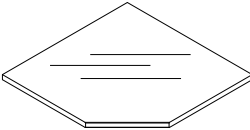
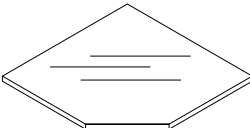
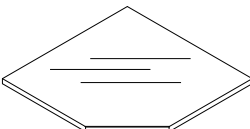
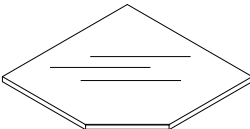
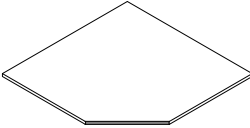
	Descrizione / Description Description / Beschreibung / Descripción	M³ Kg	32,5 mm
 <p>L 705 x P 705 x H 12 mm L 800 x P 800 x H 12 mm</p>	<p>Piano angolare in Corian® bianco White Corian® top for corner units Plan en Corian® blanc pour modules d'angle Weiß Corian® Arbeitsplatte für Eckschränke Encimera de Corian® blanco para módulos angulares</p>	- 10,3	CBA (P 705 mm)
		- 13,3	CDA (P 800 mm)
 <p>L 705 x P 705 x H 15 mm</p>	<p>Piano angolare in vetro Glass top for corner units Plan en verre pour modules d'angle Glasarbeitsplatte für Eckschränke Encimera de vidrio para módulos angulares</p>	- 18	VBA
 <p>L 705 x P 705 x H 15 mm</p>	<p>Piano angolare in vetro satinato Glass top satin for corner units Plan en verre dépoli pour modules d'angle Satinierter Glasarbeitsplatte für Eckschränke Encimera de vidrio satinado para módulos angulares</p>	- 18	XBA
 <p>L 705 x P 705 x H 15 mm</p>	<p>Piano angolare in vetro extra-chiaro Extra-clear glass top for corner units Plan en verre transparent pour modules d'angles Transparente Glasarbeitsplatte für Eckschränke Encimera de vidrio transparente para módulos angulares</p>	- 18	YBA
 <p>L 705 x P 705 x H 15 mm</p>	<p>Piano angolare in vetro extra-chiaro satinato Extra-clear glass top satin for corner units Plan en verre transparent dépoli pour modules d'angles Transparente satinierter Glasarbeitsplatte für Eckschränke Encimera de vidrio transparente satinado para módulos angulares</p>	- 18	ZBA
 <p>L 705 x P 705 x H 12 mm L 800 x P 800 x H 12 mm</p>	<p>Piano angolare in stratificato bianco White stratified top for corner units Plan en stratifié blanc pour modules d'angles Weiß Schichtstoffarbeitsplatte für Eckschränke Encimera de estratificado blanco para módulos angulares</p>	- 9	SBA (P 705 mm)
		- 11,8	SDA (P 800 mm)

Armonya - Start

Piani / Tops / Plans / Arbeitsplatten / Encimeras

Loran
everyday passion

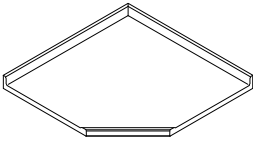
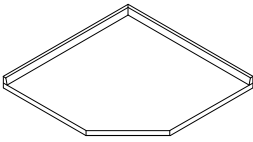
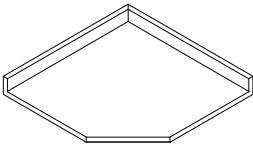
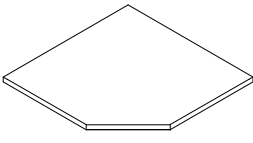
	Descrizione / Description Description / Beschreibung / Descripción	M³ Kg	Articolo Item / Article Artikel / Artículo
 <p>Piano angolare in laminato con alzatina incorporata H 45 mm Laminated top with rear trim H 45 mm Plan en laminé avec dossier H 45 mm Laminarbeitsplatte mit Aufkantung H 45 mm Encimera de laminado con elevación H 45 mm</p> <p>L 660 x P 660 x H 30 mm L 720 x P 720 x H 30 mm</p>		- 9	BAA (P 660 mm)
		- 10,5	BCA (P 720 mm)
 <p>Piano angolare in laminato con alzatina applicata ALB H 40 mm Laminated top with applied rear trim ALB H 40 mm Plan en laminé avec dossier appliqué ALB H 40 mm Laminarbeitsplatte mit aufgeklebter Aufkantung ALB H 40 mm Encimera de laminado con elevación aplicado ALB H 40 mm</p> <p>L 660 x P 660 x H 30 mm L 720 x P 720 x H 30 mm L 800 x P 800 x H 30 mm</p>		- 8,5	TAA (P 660 mm)
		- 10	TCA (P 720 mm)
 <p>Piano angolare in acciaio inox con alzatina incorporata H 70 mm Stainless steel top with rear trim H 70 mm Plan en acier inox avec dossier H 70 mm Edelstahlarbeitsplatte mit Aufkantung H 70 mm Encimera de acero inox con elevación H 70 mm</p> <p>L 720 x P 720 x H 30 mm L 800 x P 800 x H 30 mm</p>		- 13	HCA (P 720 mm)
		- 16	HDA (P 800 mm)
 <p>Piano angolare in acciaio inox senza alzatina Stainless steel top Plan en acier inox Edelstahlarbeitsplatte Encimera de acero inox</p> <p>L 720 x P 720 x H 30 mm L 800 x P 800 x H 30 mm</p>		- 12	ICA (P 720 mm)
		- 14,8	IDA (P 800 mm)

Vela - Armonya - Start

Alzatine / Splashbacks / Dosserets / Aufkantungen / Alzadas

Loran
everyday passion

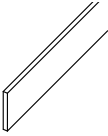
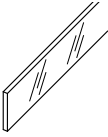
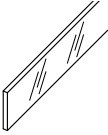
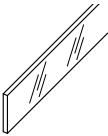
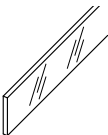
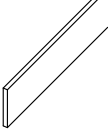
	Descrizione / Description Description / Beschreibung / Descripción	M³ Kg	Articolo Item / Article Artikel / Artículo
 SP 12 x H 80 mm SP 12 x H 12 mm	Alzatina in Corian® bianco: al metro lineare White Corian® splashback: per meter Dosseret en Corian® blanc: au mètre Weiß Corian® Aufkantung: je Meter Alzada de Corian® blanco: al m.	- 1,5	AC08 (H 80 mm)
		- 0,3	AC01 (H 12 mm)
 SP 15 x H 80 mm SP 15 x H 100 mm	Alzatina in vetro: al metro lineare Glass splashback: per meter Dosseret en verre: au mètre Glasaufkantung: je Meter Alzada de vidrio: al m.	- 3	AV08 (H 80 mm)
		- 3,8	AV10 (H 100 mm)
 SP 15 x H 80 mm SP 15 x H 100 mm	Alzatina in vetro satinato: al metro lineare Glass splashback satin: per meter Dosseret en verre dépoli: au mètre Satinierte Glasaufkantung: je Meter Alzada de vidrio satinado: al m.	- 3	AX08 (H 80 mm)
		- 3,8	AX10 (H 100 mm)
 SP 15 x H 80 mm SP 15 x H 100 mm	Alzatina in vetro extra-chiaro: al metro lineare Extra-clear glass splashback: per meter Dosseret en verre transparent: au mètre Transparente Glasaufkantung: je Meter Alzada de vidrio transparente: al m.	- 3	AY08 (H 80 mm)
		- 3,8	AY10 (H 100 mm)
 SP 15 x H 80 mm SP 15 x H 100 mm	Alzatina in vetro extra-chiaro satinato: al metro lineare Extra-clear glass splashback satin: per meter Dosseret en verre transparent dépoli: au mètre Transparente satinierte Glasaufkantung: je Meter Alzada de vidrio transparente satinado: al m.	- 3	AZ08 (H 80 mm)
		- 3,8	AZ10 (H 100 mm)
 SP 12 x H 80 mm SP 12 x H 100 mm	Alzatina in stratificato bianco: al metro lineare White stratified splashback: per meter Dosseret en stratifié blanc: au mètre Weiß Schichtstoffaufkantung: je Meter Alzada de estratificado blanco: al m.	- 1,5	AS08 (H 80 mm)
		- 1,8	AS10 (H 100 mm)

	Descrizione / Description Description / Beschreibung / Descripción	M³ Kg	Articolo Item / Article Artikel / Artículo
	<p>Set collegamento 2 piani laminato Worktop-connection set Set pour la liaison de 2 plans de travail Set für Zusammenbau von Arbeitsplatten Juego para la unión de las 2 encimeras</p>		SCP
	<p>Arrotondamento spigolo del piano Corner-rounding for top Angle arrondi pour le plan de travail Abgerundete Kanten der Arbeitsplatte Angulo redondeado de la encimera</p>		
	Corian®		ARC
	Vetro / Glass / Verre / Glas / Vidrio		ARV
	Stratificato / Stratified / Stratifié / Schichtstoff / Estratificado		ARS
	Laminato / Laminate / Laminé / Laminat / Laminado		ARP
	Acciaio inox / Stainless steel / Acier Inox Edelstahl / Acero inoxidable		ARI
	<p>Taglio obliquo su piano Special cut of top Découpe spéciale sur le plan de travail Sonderschnitt der Arbeitsplatte Corte especial sobre la encimera</p>		
	Corian®		TSC
	Vetro / Glass / Verre / Glas / Vidrio		TSV
	Stratificato / Stratified / Stratifié / Schichtstoff / Estratificado		TSS
	Laminato / Laminate / Laminé / Laminat / Laminado		TSP
	Acciaio inox / Stainless steel / Acier Inox Edelstahl / Acero inoxidable		TSI
	<p>Taglio a "L" su piano Special cut of top Découpe spéciale sur le plan de travail Sonderschnitt der Arbeitsplatte Corte especial sobre la encimera</p>		
	Corian®		T1C
	Vetro / Glass / Verre / Glas / Vidrio		T1V
	Stratificato / Stratified / Stratifié / Schichtstoff / Estratificado		T1S
	Laminato / Laminate / Laminé / Laminat / Laminado		T1P
	Acciaio inox / Stainless steel / Acier Inox Edelstahl / Acero inoxidable		T1I

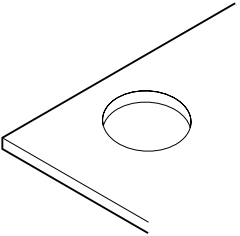
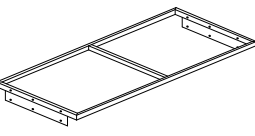
	Descrizione / Description Description / Beschreibung / Descripción	M³ Kg	Articolo Item / Article Artikel / Artículo
	Foro Ø 150 mm su piano, per rifiuti Waste hole Ø 150 mm for top Trou passage déchets Ø 150 mm, pour plan Abfallloch Ø 150 mm für Arbeitsplatte Agujero Ø 150 mm para la basura, sobre encimera		
	Corian®		FRC
	Vetro / Glass / Verre / Glas / Vidrio		FRV
	Stratificato / Stratified / Stratifié / Schichtstoff / Estratificado		FRS
	Laminato / Laminare / Laminé / Laminat / Laminado		FRT
Acciaio inox / Stainless steel / Acier Inox Edelstahl / Acero inoxidable		FRA	
	Telaio supporto piano a sbalzo per piani Corian®, vetro, stratificato: al metro lineare Frame to support the top in Corian®, glass, stratified Châssis pour soutenir le plan en Corian®, verre, stratifié Rahmen für Arbeitsplatte aus Corian®, Glas, Schichtstoff Frame para apoyar las encimeras de Corian®, vidrio, estratificado		STS

Vela - Armonya - Start

Lavelli / Sinks / Eiers / Waschbecken / Lavabos

Loran
everyday passion

Descrizione / Description
Description / Beschreibung / Descripción

M³
Kg

Articolo
Item / Article
Artikel / Artículo

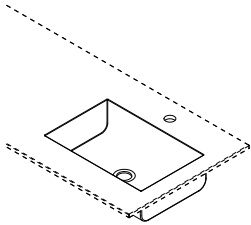

Lavello integrato in Corian®

Integrated Corian® sink
Evier intégré en Corian®
Integrierte Waschbecken aus Corian®
Lavabo integrado de Corian®

L 400 x P 260 x H 110 mm

VIC

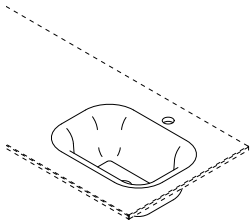

Lavello termoformato in Corian®

Integrated thermoformed Corian® sink
Evier intégré thermoformé en Corian®
Integriertes tiefgezogenes Waschbecken aus Corian®
Lavabo integrado termoformato de Corian®

L 400 x P 300 x H 130 mm

VTC

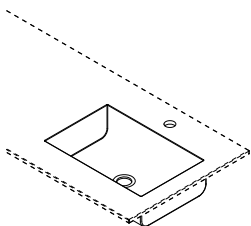

Lavello sottopiano in acciaio inox, per piani in Corian® e stratificato

Undermont stainless steel sink, for Corian® and stratified top
Evier en inox, pour plans en Corian® et stratifié
Unterbauedelstahlwaschbecken, für Arbeitsplatte aus Corian®
und Schichtstoff
Lavabo bajo encimera de acero para encimeras de
Corian® y estratificado

L 400 x P 270 x H 195 mm

VFA

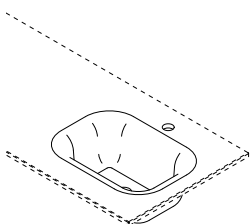

Lavello integrato in vetro

Integrated glass sink
Evier intégré en verre
Integriertes, tiefgezogenes Glaswaschbecken
Lavabo integrado de vidrio

NB: piani lineari L 2800 mm max. / Straight tops L 2800 mm max. /
Plans linéaires L 2800 mm max. / Gerade Arbeitsplatte L 2800 mm max. /
Encimera lineal L 2800 mm max.

L 400 x P 300 x H 130 mm

VIV

Vela - Armonya - Start

Lavelli / Sinks / Evers / Waschbecken / Lavabos

Loran
everyday passion

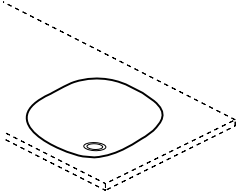
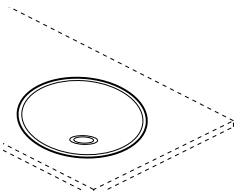
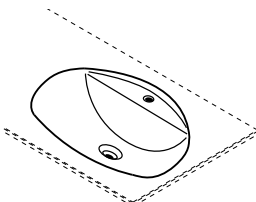
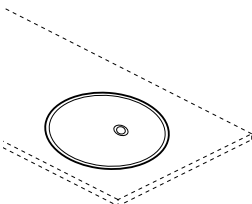
	Descrizione / Description Description / Beschreibung / Descripción	M³ Kg	Articolo Item / Article Artikel / Artículo
	<p>Lavello integrato in vetro (NO satinato / NO angolare) Integrated glass sink (NOT satin / NOT corner) Evier intégré en verre (PAS dépoli / PAS d'angle) Integrierte Glaswaschbecken (NICHT satiniert / NICHT Ecke) Lavabo integrado de vidrio (NO satinado / NO angular)</p> <p>NB: piani lineari L 2100 mm max. (solo all'estremità sx o dx del piano) / Straight tops L 2100 mm max. (only at the right or left end of the top) Plans linéaires L 2100 mm max. (uniquement à l'extrémité gauche ou droite du plan) Gerade Arbeitsplatte L 2100 mm max. (nur am linken oder rechten Ende der Arbeitsplatte) Encimera lineal L 2100 mm max. (sólo en el extremo izdo. o dcho. de la encimera)</p>		
L 320 x P 320 mm			VI
	<p>Lavello a semisfera in acciaio inox sopra piano Top mounted stainless steel sink Evier en inox sur plan Aufgesetztes Edelstahlwaschbecken Lavabo de acero sobre encimera</p> <p>NB: si consiglia il rubinetto RB3 / mixer RB3 suggested / robinet RB3 conseillé / Wasserhahn RB3 empfohlen / se aconseja el grifo RB3</p>		
Ø 340 mm - H 160 mm		1	VAS
	<p>Lavello in ceramica a filo piano Flush ceramic bowl Evier porcelaine collée sous le plan Porzellanwaschbecken bündig mit der Arbeitsplatte Lavabo de cerámica a ras de la encimera</p>		
	Laminato / Laminato / Laminé / Laminat / Laminado	7,2	VCF
L 455 x P 405 mm	Stratificato / Stratified / Stratifié / Schichtstoff / Estratificado	7,2	VCS
	<p>Lavello in acciaio smaltato Enamel steel sink Evier en acier inox émaillé Aufgesetztes emailiertes Stahl-Waschbecken Lavabo de acero esmaltado</p>		
Ø 340 mm - H 160 mm		1	VSS

	Descrizione / Description Description / Beschreibung / Descripción	M³ Kg	Articolo Item / Article Artikel / Artículo
--	--	-----------------------------------	---

STERIL CENTER (per piani prof. 505 - 520 - 600 mm)

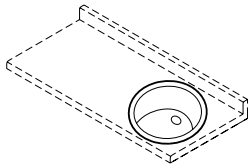

Lavello circolare in acciaio inox sopra piano (o sottopiano per piani in Corian® e stratificato)

Top mounted stainless steel sink
(or undermount for Corian® and stratified top)
Evier en inox sur plan
(ou collée sous le plan pour plans en Corian® et stratifié)
Aufgesetztes Edelstahlwaschbecken
(oder unterbau montiert für Arbeitsplatte aus Corian® und Schichtstoff)
Lavabo de acero sobre encimera
(o bajo encimera para encimeras de Corian® o estratificado)

Ø 380 - H 180 mm

-
1

V1S

STERIL CENTER (per piani prof. 600 mm)

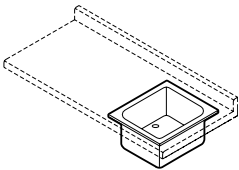

Lavello rettangolare in acciaio inox sopra piano

Top mounted stainless steel sink
Evier en inox sur plan
Aufgesetztes Edelstahlwaschbecken
Lavabo de acero sobre encimera

L 360 x P 360 x H 170 mm

-
2,5

V2S

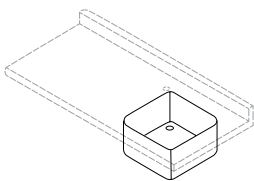

Lavello rettangolare in acciaio inox a filo piano (per piani in Corian® e stratificato)

Stainless steel sink (for Corian® and stratified top)
Evier en inox collée sous le plan
(pour plans en Corian® et stratifié)
Edelstahlwaschbecken bündig mit der Arbeitsplatte
(für Arbeitsplatte aus Corian® und Schichtstoff)
Lavabo de acero a ras de la encimera
(para encimeras de Corian® o estratificado)

L 340 x P 400 x H 200 mm

-
4,5

V2SF

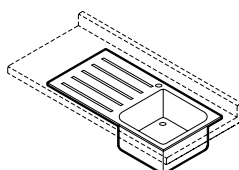

Lavello in acciaio inox e sgocciolatoio da incasso

Stainless steel sink with draining board
Evier en inox avec égouttoir
Edelstahlwaschbecken mit Abtropfblech
Lavabo de acero con escurridor

L 860 x P 500 x H 170 mm

-
3,5

V3S

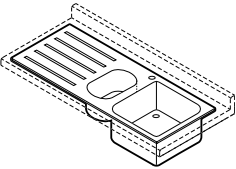
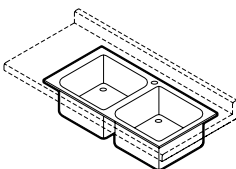
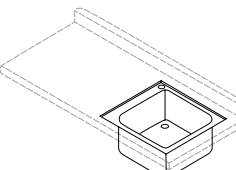
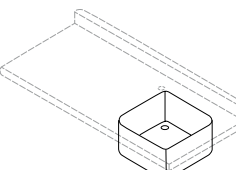
	Descrizione / Description Description / Beschreibung / Descripción	M³ Kg	Articolo Item / Article Artikel / Artículo
 <p>L 1000 x P 500 x H 170 mm</p>	<p>Lavello in acciaio inox con vaschetta e sgocciolatoio soprapiano (per mobile sottolavello L 1000)</p> <p>Stainless steel sink with draining board (for sink unit L 1000)</p> <p>Evier en inox avec égouttoir (pour module lavabo L 1000)</p> <p>Edelstahlwaschbecken mit Abtropfblech (für Waschbeckenschrank L 1000)</p> <p>Lavabo de acero con escurridor (para módulo lavabo L 1000)</p>	<p>-</p> <p>4,5</p>	<p>V4S</p>
 <p>L 860 x P 500 x H 170 mm</p>	<p>Doppio lavello in acciaio inox soprapiano (per mobile sottolavello L 1000)</p> <p>Double stainless steel sink (for sink unit L 1000)</p> <p>Double evier en inox (pour module lavabo L 1000)</p> <p>Doppeledelstahlwaschbecken (für Waschbeckenschrank L 1000)</p> <p>Doble lavabo de acero (para módulo lavabo L 1000)</p>	<p>-</p> <p>4,5</p>	<p>V5S</p>
 <p>L 400 x P 400 x H 200 mm</p>	<p>Lavello in acciaio inox con abbassamento incorporato al piano inox</p> <p>Stainless steel sink integrated in the stainless steel top</p> <p>Evier en inox incorporé dans le plan en acier inox</p> <p>Edelstahlwaschbecken in die Edelstahlarbeitsplatte integriert</p> <p>Lavabo de acero incorporado con la encimera de acero</p>	<p>-</p> <p>5,5</p>	<p>V1A</p>
 <p>L 400 x P 400 x H 200 mm</p>	<p>Lavello in acciaio inox incorporato al piano inox</p> <p>Stainless steel sink integrated in the stainless steel top</p> <p>Evier en inox incorporé dans le plan en acier inox</p> <p>Edelstahlwaschbecken in die Edelstahlarbeitsplatte integriert</p> <p>Lavabo de acero incorporado con la encimera de acero</p>	<p>-</p> <p>5</p>	<p>V1I</p>

Vela - Armonya - Start

Rubinetti / Mixers / Robinets / Wasserhähne / Grifos

Loran
everyday passion

Descrizione / Description
Description / Beschreibung / Descripción

M³
Kg

Articolo
Item / Article
Artikel / Artículo

Per lo STUDIO / For DENTAL OFFICE /- Pour le CABINET / Für PRAXIS / Por el ESTUDIO

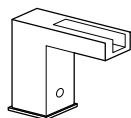

Rubinetto "a cascata" con fotocellula

Mixer "a cascata" with photoelectric cell
Robinet électronique "a cascata" à photocellule
Elektronische Wasserhahn "a cascata" mit Fotozelle
Grifo "a cascata" con fotocélula

-
4

RB8

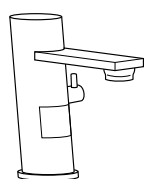

Rubinetto con fotocellula

Mixer with photoelectric cell
Robinet électronique à photocellule
Elektronische Wasserhahn mit Fotozelle
Grifo con fotocélula

-
3

RB7

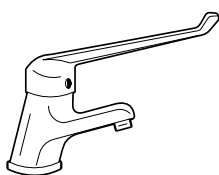

Rubinetto cromato a leva lunga

Chromed mixer with long lever
Robinet chromé à levier long
Verchromte Wasserhahn mit langem Hebel
Grifo cromado con palanca larga

-
1,5

RB2

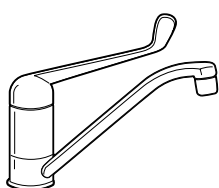

Rubinetto cromato con collo lungo e leva lunga

Chromed mixer with long neck and long lever
Robinet chromé à col long et levier long
Verchromte Langrohr- und Langhebel-Wasserhahn
Grifo cromado con caño largo y palanca larga

-
1,5

RB3

Armonya - Start

Rubinetti / Mixers / Robinets / Wasserhähne / Grifos

Loran
everyday passion

Descrizione / Description
Description / Beschreibung / Descripción

M³
Kg

Articolo
Item / Article
Artikel / Artículo

Per STERIL CENTER / For STERIL CENTER / Pour STERIL CENTER / Für STERIL CENTER / Por STERIL CENTER

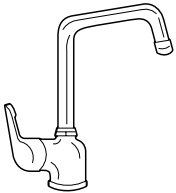

Rubinetto cromato con collo alto

Chromed mixer
Robinet chromé
Verchromte Wasserhahn
Grifo cromado

-
1,5

RB4

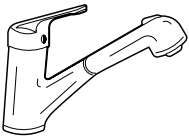

Rubinetto cromato con doccetta estraibile

Chromed mixer with pull-out showerhead
Robinet chromé avec douchette extractible
Verchromte Wasserhahn mit abnehmbarer Dusche
Grifo cromado con ducha extraíble

-
2,7

RB5

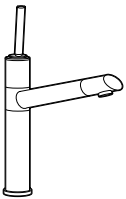

Rubinetto in acciaio AISI316

Steel mixer AISI316
Robinet en acier AISI316
Edelstahlwasserhahn AISI316
Grifo de acero AISI316

-
2

RB6

Armonya - Start

Cassetti / Drawers / Tiroirs / Schubladen / Cajones

Loran
everyday passion

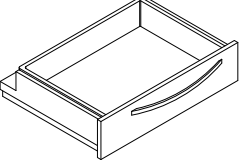
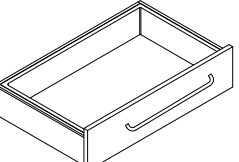
	Descrizione / Description Description / Beschreibung / Descripción	M³ Kg	Articolo Item / Article Artikel / Artículo
	CASSETTO ARMONYA Drawer Armonya Tiroir Armonya Schublade Armonya Cajón Armonya	A) H 60	$\frac{-}{4,1}$ CAA02
		B) H 121	$\frac{-}{5}$ CAB02
		C) H 182	$\frac{-}{5,4}$ CAC02
		D) H 245	$\frac{-}{5,8}$ CAE06
	CASSETTO START Drawer Start Tiroir Start Schublade Start Cajón Start	A) H 60	$\frac{-}{3}$ CAA05
		B) H 121	$\frac{-}{4}$ CAB05
		C) H 182	$\frac{-}{4,3}$ CAC05
		D) H 245	$\frac{-}{4,7}$ CAE05

Armonya - Start

Bacinelle / Trays / Intérieurs de tiroir / Einsätze / Bandejas

Loran
everyday passion

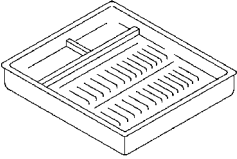
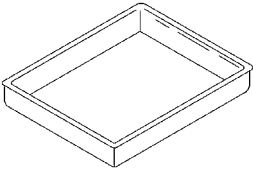
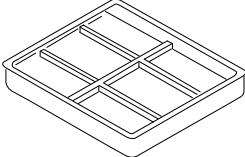
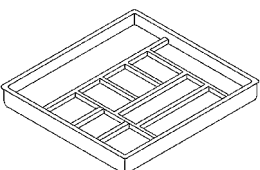
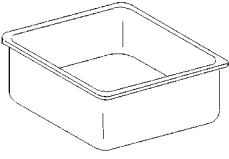
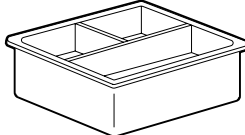
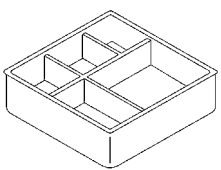
	Descrizione / Description Description / Beschreibung / Descripción	M³ Kg	Articolo Item / Article Artikel / Artículo
	BACINELLA con rastrelliera portastrumenti, per cassetto A Instrument compartment drawer tray, for drawer A Intérieur de tiroir porte-instruments, pour tiroir A Einsatz mit Instrumentenhalter, für Schublade A Bandeja porta instrumentos, para cajón A	- 0,4	1A
	BACINELLA piana, per cassetto A Flat drawer tray, for drawer A Intérieur de tiroir bas, pour tiroir A Niedriger Einsatz, für Schublade A Bandeja plana, para cajón A	- 0,4	2A
	BACINELLA a 6 settori, per cassetto A Drawer tray with 6 compartments, for drawer A Intérieur de tiroir à 6 secteurs, pour tiroir A 6-Fächern Einsatz, für Schublade A Bandeja con 6 sectores, para cajón A	- 0,4	3A
	BACINELLA a 10 settori, per cassetto A Drawer tray with 10 compartments, for drawer A Intérieur de tiroir à 10 secteurs, pour tiroir A 10-Fächern Einsatz, für Schublade A Bandeja con 10 sectores, para cajón A	- 0,4	7A
	BACINELLA piana, per cassetto B Flat drawer tray, for drawer B Intérieur de tiroir bas, pour tiroir B Niedriger Einsatz, für Schublade B Bandeja plana, para cajón B	- 0,5	9B
	BACINELLA a 3 settori, per cassetto B Drawer tray with 3 compartment, for drawer B Intérieur de tiroir à 3 secteurs, pour tiroir B 3-Fächern Einsatz, für Schublade B Bandeja con 3 sectores, para cajón B	- 0,5	10B
	BACINELLA a 5 settori, per cassetto B Drawer tray with 5 compartment, for drawer B Intérieur de tiroir à 5 secteurs, pour tiroir B 5-Fächern Einsatz, für Schublade B Bandeja con 5 sectores, para cajón B	- 0,5	11B



Armonya - Start

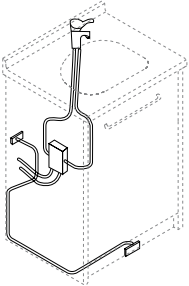
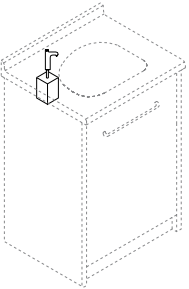
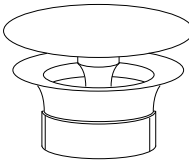
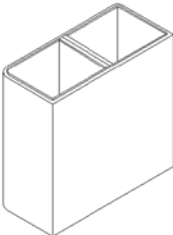
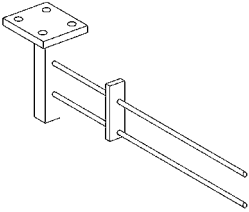

Accessori / Accessories / Accessoires / Zubehör / Accesorios

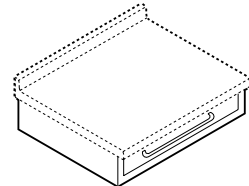
Loran
everyday passion

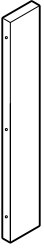
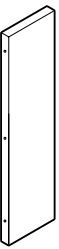
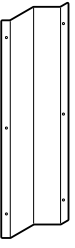
	Descrizione / Description Description / Beschreibung / Descripción	M³ Kg	Articolo Item / Article Artikel / Artículo
	<p>Kit comando elettromagnetico 24V</p> <p>24V electromagnetic control kit</p> <p>Kit commande électromagnétique 24V pour l'eau</p> <p>Elektromagnetischer Wasserauslöser 24V</p> <p>Kit de control electromagnético 24V</p>	<p>-</p> <p>1</p>	<p>KEL</p>
	<p>Distributore di sapone</p> <p>Soap dispenser</p> <p>Distributeur de savon</p> <p>Seifenspender</p> <p>Distribudor de jabón</p>	<p>-</p> <p>0,24</p>	<p>DSA</p>
	<p>Piletta Click-Clack</p> <p>Click-Clack waste</p> <p>Click-Clack fuite</p> <p>Drain Klick-Klack</p> <p>Vaciador Click-Clack</p>	<p>-</p> <p>-</p>	<p>PIL</p>
 <p>L 370 x P 200 x H 380 mm</p>	<p>Portarifiuti doppio per modulo sottolavello</p> <p>Double rubbish bin for sink unit</p> <p>Poubelle double pour module lavabo</p> <p>Doppelabfalleimer für Waschbeckenschrank</p> <p>Doble cubo de basura para el módulo lavabo</p>	<p>-</p> <p>2,5</p>	<p>POD</p>
	<p>Porta asciugamani a telescopio</p> <p>Telescope-shaped towel rail</p> <p>Support essuie-mains télescopique</p> <p>Ausziehbarer Handtuchhalter</p> <p>Portatoallas extraíble</p>	<p>-</p> <p>0,5</p>	<p>PC</p>

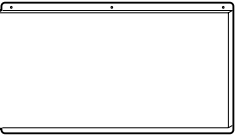
	Descrizione / Description Description / Beschreibung / Descripción	M³ Kg	Articolo Item / Article Artikel / Artículo
	<p>Vetro a filo cassetto A</p> <p>Glass-top for drawer A Verre installé à fil sur tiroir A Glas bündig mit der Schublade A Tapa vidrio a ras del cajón A</p>	- 3	OFC
	<p>Negatoscopio per cassetto B</p> <p>Negatoscope for drawer B Négatoscope pour tiroir B Röntgenfilmbetrachter für Schublade B Negatoscopio para cajón B</p>	- 3	CN
	<p>Alloggio per micromotore, nel cassetto B, con caviglia e predisposizione per l'aspirazione</p> <p>Compartment for micromotor, in drawer B, with peg and setting for suction apparatus Emplacement pour micromoteur, dans le tiroir B, avec cheville et prédisposition pour l'aspiration Schublade B mit Sitz für Mikromotor, Feilkloben und Vorrüstung für Absauganlage Compartimiento para micromotor, en el cajón B, con clavija y predisposición para la aspiración</p>	- 3	CSA
	<p>Cassettiera monocassetto A</p> <p>Single-drawer A unit Module mono-tiroir A Unterbaufähige Schublade A Cajonera monocajón A</p>	- 13	CMA-A
L 500 x P 460 x H 110 mm	START	- 12	CMA-S
	<p>Cassettiera monocassetto B</p> <p>Single-drawer B unit Module mono-tiroir B Unterbaufähige Schublade B Cajonera monocajón B</p>	- 14	CMB-A
L 500 x P 460 x H 175 mm	START	- 12	CMB-S

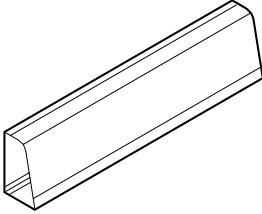
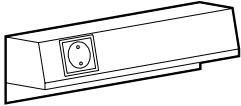
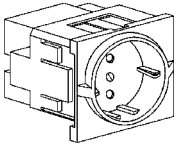
	Descrizione / Description Description / Beschreibung / Descripción	M³ Kg	Articolo Item / Article Artikel / Artículo
	<p>Pannello di chiusura da 70 a 150 mm</p> <p>Closing panel from 70 to 150 mm Cache de fermeture de 70 à 150 mm Verschlußverkleidung von 70 bis 150 mm Panel de cierre desde 70 hasta 150 mm</p>		PC1
H min 675 - H max 885 mm			
	<p>Pannello di chiusura da 160 a 250 mm</p> <p>Closing panel from 160 to 250 mm Cache de fermeture de 160 à 250 mm Verschlußverkleidung von 160 bis 250 mm Panel de cierre desde 160 hasta 250 mm</p>		PC2
H min 675 - H max 885 mm			
	<p>Pannello di chiusura ad angolo</p> <p>Corner closing panel Cache de fermeture pour angle Eckverschlußverkleidung Panel de cierre en ángulo</p>		PC3
H min 675 - H max 885 mm			
	<p>Pannello chiusura posteriore ai mobili: al metro lineare</p> <p>Furniture back panel: per meter Cache arrière meubles: au mètre Hintere Platte: je Meter Panel de cierre posterior: al m.</p>		PC4
H min 675 - H max 885 mm			
	<p>Pannello chiusura inox fra piano e pensili: al metro lineare</p> <p>Stainless steel closing panel between top and suspended units: per meter Panneau de jonction en acier inox entre plan et éléments muraux: au mètre Edelstahlverschlußverkleidung zwischen Arbeitsplatte und Hängeschränken: je Meter Panel de cierre de acero entre encimera y elementos colgantes: al m.</p>		PC5
P 20 x H 500 mm			

	Descrizione / Description Description / Beschreibung / Descripción	M³ Kg	Articolo Item / Article Artikel / Artículo
 <p>P 20 x H 40 mm</p>	<p>Alzatina bianca: al metro lineare</p> <p>White splashback: per meter Dossieret blanc: au mètre Weiße Aufkantung: je Meter Alzada blanca: al m.</p>	- 0,5	ALB
 <p>P 63 x H 75 mm</p>	<p>Canalina tecnica in alluminio: al metro lineare</p> <p>Aluminium raceway: per meter Canalisation technique en aluminium: au mètre Technikkanal aus Aluminium: je Meter Canal técnico de aluminio: al m.</p>	- 1,2	CVE
	<p>Presa di corrente Schuko per canalina tecnica CVE</p> <p>Schuko-socket for CVE Prise de courant Schuko pour CVE Schuko-Steckdose für CVE Toma de corriente Schuko para CVE</p>		PCS
 <p>L 300/400 x P 400 x H 135 mm</p>	<p>Piano estraibile con 1 presa di corrente Schuko</p> <p>Pull-out shelf with 1 Schuko socket Tirette avec 1 prise de courant Schuko Auszug ausgestattet mit 1 Schuko-Steckdose Estante extraíble con 1 toma de corriente Schuko</p>	- 4	PE/3 (L 300 mm)
		- 5	PE/4 (L 400 mm)

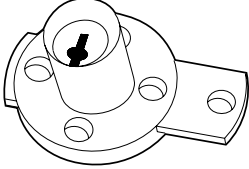
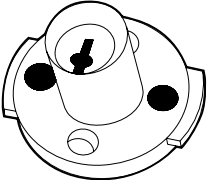
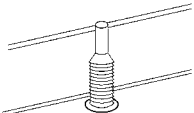
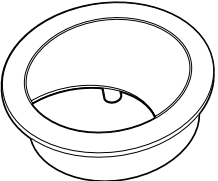
	Descrizione / Description Description / Beschreibung / Descripción	M³ Kg	Articolo Item / Article Artikel / Artículo
	<p>Serratura per serie cassetti</p> <p>Lock for set of drawers Serrure pour série de tiroirs Sicherheitsschloß für Schubladen Cerradura para serie de cajones</p>		SEC
	<p>Serratura per portina</p> <p>Door lock Serrure pour porte Sicherheitsschloß für Tür Cerradura para puerta</p>		SEP
	<p>Siringa aria a scomparsa sul piano</p> <p>Hide-away air syringe for top Soufflette air escamotable sur le plan Versenkbare Luftdüse auf der Arbeitsplatte Jeringa de aire escamoteable sobre la encimera</p>		SAR
	<p>Boccola passacavo con chiusura</p> <p>Cable bush with plug Manchon passe-câbles avec fermeture Kabeldurchführung mit Verschluss Casquillo pasacables con cierre</p>	<p>Ø 60 mm</p>	BOP

Armonya - Start

Accessori / Accessories / Accessoires / Zubehör / Accesorios

Loran
everyday passion

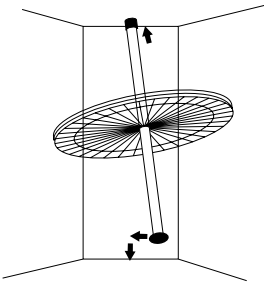
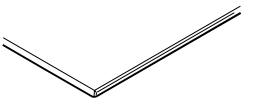
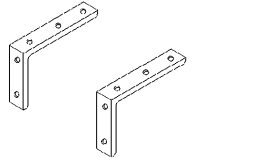
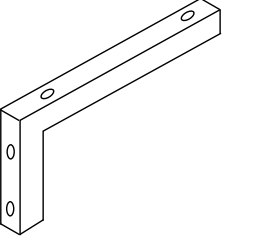
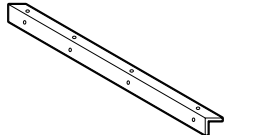
	Descrizione / Description Description / Beschreibung / Descripción	M³ Kg	Articolo Item / Article Artikel / Artículo
 <p>Ø 650 mm</p>	<p>Cestello rotante inox per mobile angolare</p> <p>Stainless steel swivel basket for corner unit Casier roulant en inox pour module d'angle Drehkorb aus Edelstahl für Eckschrank Cesto giratorio de acero inoxidable para módulo angular</p>	<p>-</p> <p>3</p>	<p>CRA</p>
	<p>Bordo in gomma bianco per piano laminato: supplemento</p> <p>White rubber edge for laminated top: upcharge Caoutchouc blanc pour plan en laminé: supplément Weiße Gummykante für Laminatarbeitsplatte: Aufpreis Borde de goma blanco para encimera de laminado: sobreprecio</p>		<p>DBB</p>
	<p>Coppia staffe di sostegno mensola</p> <p>Double shelf brackets Paire d'équerres de support pour étagère Doppelstützbügel für Regal Par de estribos de sostén de la repisa</p>		<p>CSM</p>
 <p>L 40 x P 320 x H 180 mm L 40 x P 430 x H 240 mm</p>	<p>Supporto mensola in tubo quadro cromato</p> <p>Chromed shelf brackets Equerre chromée de support pour étagère Verchromte Stützbügel für Regal Estribo cromado de sostén de la repisa</p>	<p>SMC2 (P 320 mm)</p> <hr/> <p>SMC1 (P 430 mm)</p>	
 <p>L 350 x P 40 x H 40 mm</p>	<p>Squadretta a "L" di sostegno piano</p> <p>"L" top bracket Equerre à "L" de soutien pour plan "L-förmige" Stützbügel für Arbeitsplatte Estribo en "L" de sostén de la encimera</p>		<p>SSL</p>

Armonya - Start

Accessori / Accessories / Accessoires / Zubehör / Accesorios

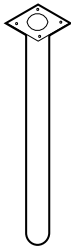
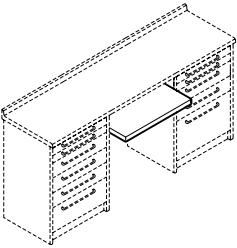
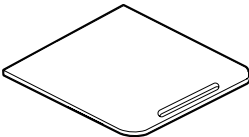
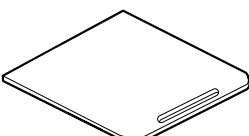
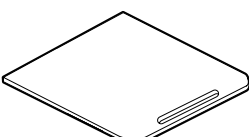

Loran
everyday passion

	Descrizione / Description Description / Beschreibung / Descripción	M³ Kg	Articolo Item / Article Artikel / Artículo
 <p>Ø 60 H min 785 - H max 875 mm</p>	<p>Supporto in tubolare per piano</p> <p>Tube top bracket</p> <p>Support en tube pour plan</p> <p>Rundrohrbeine für Arbeitsplatte</p> <p>Soporte en tubular para la encimera</p>	- 8	STP
 <p>L 500 x P 400 x H 30 mm</p>	<p>Piano estraibile in laminato per tastiera</p> <p>Pull-out laminated top for keyboard</p> <p>Tirette en laminé pour clavier</p> <p>Ausziehbare Platte für Tastatur</p> <p>Estante extraible de laminado para teclado</p>	- 4,5	PPT
 <p>L 502x P 509 x H 12 mm</p>	<p>Piano sagomato in Corian® bianco per servomobile</p> <p>White Corian® shaped top for movable unit</p> <p>Plan façonné en Corian® blanc pour module mobile</p> <p>Geformte Arbeitsplatte aus weißem Corian® für Rollenschrank</p> <p>Encimera perfilada de Corian® blanco para módulo móvil</p>	- 5,2	PSA
 <p>L 502x P 509 x H 12 mm</p>	<p>Piano sagomato in stratificato bianco per servomobile</p> <p>White stratified shaped top for movable unit</p> <p>Plan façonné en stratifié blanc pour module mobile</p> <p>Geformte Arbeitsplatte aus weißem Schichtstoff für Rollenschrank</p> <p>Encimera perfilada de estratificado blanco para módulo móvil</p>	- 4,5	PS06
 <p>L 502 x P 502 x H 15 mm</p>	<p>Piano sagomato in vetro per servomobile</p> <p>Glass shaped top for movable unit</p> <p>Plan façonné en verre pour module mobile</p> <p>Geformte Glasarbeitsplatte für Rollenschrank</p> <p>Encimera perfilada de vidrio para módulo móvil</p>	- 9	PSB
			<p>Extra-chiaro / Extra clear / Transparent Transparent / Extra-claro</p> <p>Satinato / Satin / Dépoli Satinert / Satinado</p>

Armonya - Start

Accessori / Accessories / Accessoires / Zubehör / Accesorios

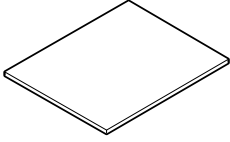
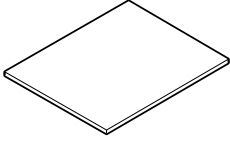
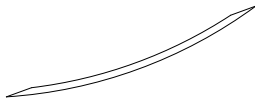
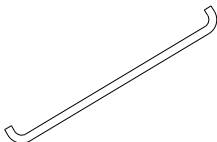
Loran
everyday passion

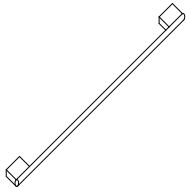
	Descrizione / Description Description / Beschreibung / Descripción	M³ Kg	Articolo Item / Article Artikel / Artículo
	<p>Piano in vetro sp. 6 mm per servomobile, solo verde acqua</p> <p>Glass top th. 6 mm colour for movable unit, only verde acqua Plan en verre ép. 6 mm pour module mobile, seulement verde acqua Glasarbeitsplatte St. 6 mm für Rollenschrank, nur verde acqua Encimera de vidrio es. 6 mm para módulo móvil, solo verde acqua</p>	- 3,3	POB
	<p>Piano in vetro sp. 10 mm per servomobile</p> <p>Glass top th. 10 mm colour for movable unit Plan en verre ép. 10 mm pour module mobile Glasarbeitsplatte St. 10 mm für Rollenschrank Encimera de vidrio es. 10 mm para módulo móvil</p>	- 5,5	PSB1
	<p>Maniglia Armonya alluminio naturale o verniciata</p> <p>Armonya handle: aluminium or painted Poignée Armonya: aluminium ou peint Griff Armonya: Aluminium oder lackiert Tirador Armonya: aluminio o pintado</p>	- -	MAAR
	<p>Maniglia Start alluminio naturale o verniciata</p> <p>Start handle: aluminium or painted Poignée Start: aluminium ou peint Griff Start: Aluminium oder lackiert Tirador Start: aluminio o pintado</p>	- -	MABF
	<p>Maniglia traino alluminio naturale o verniciata</p> <p>Pull handle: aluminium or painted Poignée d'angle: aluminium ou peint Ziehen Griff: Aluminium oder lackiert Tirador: aluminio o pintado</p>	- -	MABM
	<p>Maniglia FAM in alluminio</p> <p>Aluminium handle FAM Poignée en aluminium FAM FAM Aluminiumgriff Tirador FAM de aluminio</p>	- -	MA3

Extra-chiaro / Extra clear / Transparent
Transparent / Extra-claro

Satinato / Satin / Dépoli
Satinert / Satinado

Armonya - Start - Steril Center

Impiantistica / Plant construction / Détails d'installation

Anlagentechnik / Plantas técnicas

Loran
everyday passion

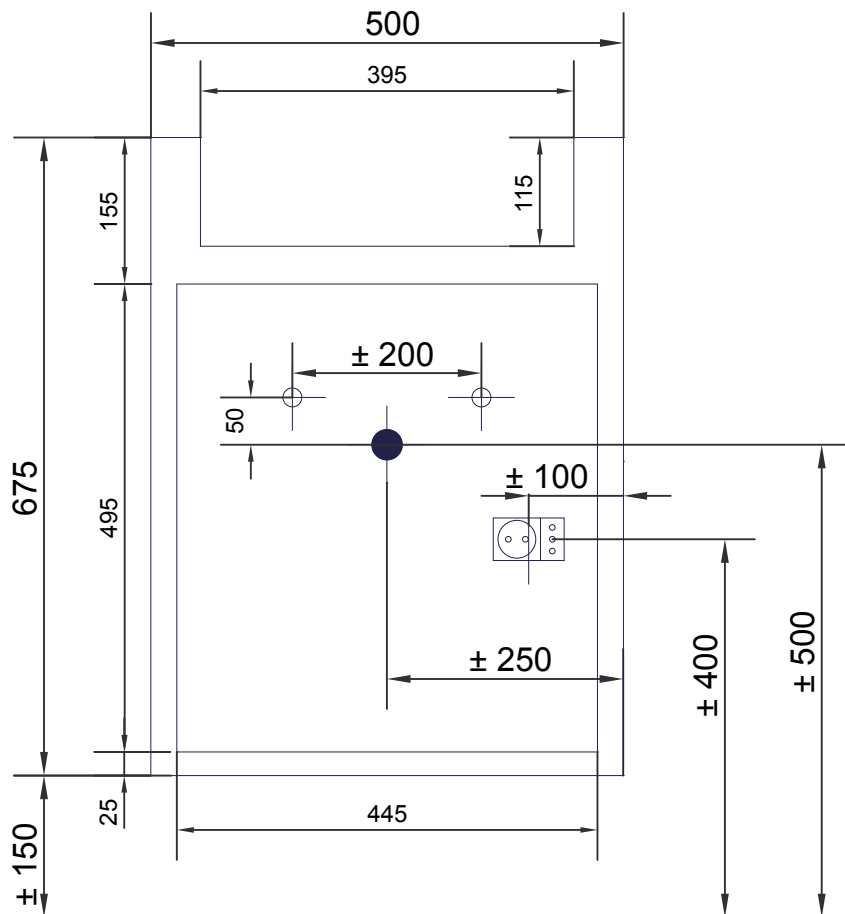









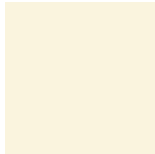





Colori

Colors / Couleurs / Farben / Colores

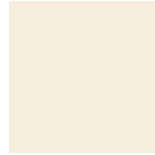
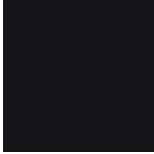
Loran
everyday passion

Finiture verniciate / Painted finishes / Finitions peintes / Lackierten Ausführungen / Acabados pintados

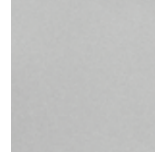
						
BIANCO	RAL 1015	RAL 1018	RAL 1023	RAL 2001	RAL 2012	RAL3000
						
RAL 3004	RAL 3016	RAL 4002	RAL 4006	RAL 5000	RAL 5002	RAL 5010
						
RAL 5012	RAL 5014	RAL 5022	RAL 5024	RAL 6000	RAL 6019	RAL 6027
						
RAL 7016	RAL 7022	RAL 7038	RAL 7045	RAL 8019	RAL 9001	RAL 9002
						
RAL 9005	SILVER	APRICOT	602 PLA	C3526	GLICINE	SILBER METALLIC

Colorazioni speciali con maggiorazione di prezzo / Special colors with upcharge / Couleurs spéciales avec supplément de prix / Sonderfarben gegen einem Aufpreis / Coloraciones especiales disponibles por un cargo adicional

Colori piani in vetro / Colors of the glass tops / Couleurs des plans en verre / Farben der Glasarbeitsplatten / Colores de las encimeras de vidrio

Vetro extra-chiaro / Extra clear glass / Verre transparent / Transparent Glas / Vidrio transparente

						
TURCHESE	LIMONE	VERDE ACQUA	VERDE	GIALLLO	AZZURRO MEDITERRANEO	GLICINE
						
CELESTE	BLU CINA	ROSSO GRANATA	ROSSO VENEZIANO	SALMONE	GIALLLO NEVADA	BIANCO

Questo campionario deve essere considerato solo come guida indicativa del colore e non può essere utilizzato come riferimento originale per la produzione e la valutazione di superfici colorate.

This sample should only be considered as an indicative colour guide and cannot be used as an original reference for the production and assessment of colored surfaces.

Ce nuancier ne sert qu'à donner une idée des différents coloris et ne doit en aucun cas être utilisé comme référence originale pour la production et l'évaluation des surfaces colorées.

Diese Farbmuster sind unverbindlich und können vom Original Farbton der hergestellten Oberflächen abweichen.

Esta muestra de colores debe considerarse sólo como una guía indicativa del color, y no puede utilizarse como referencia original para la producción y evaluación de las superficies pintadas.