

Cassetti
Drawers / Tiroirs
Schubladen / Cajones

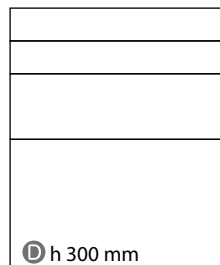

Cassetti
Drawers / Tiroirs
Schubladen / Cajones

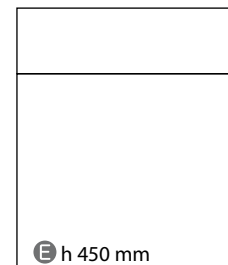

Modulo sottolavello
Sink unit / Module lavabo
Waschbeckenschrank
Módulo bajo lavabo

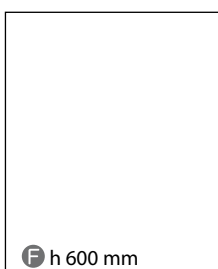

Anta
Door / Porte
Tür / Puerta

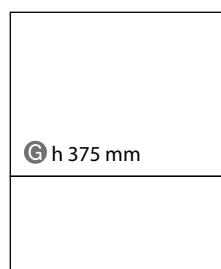

Anta a ribalta
Hide-away door
Porte basculante
Versenkbare Tür
Puerta escamoteable

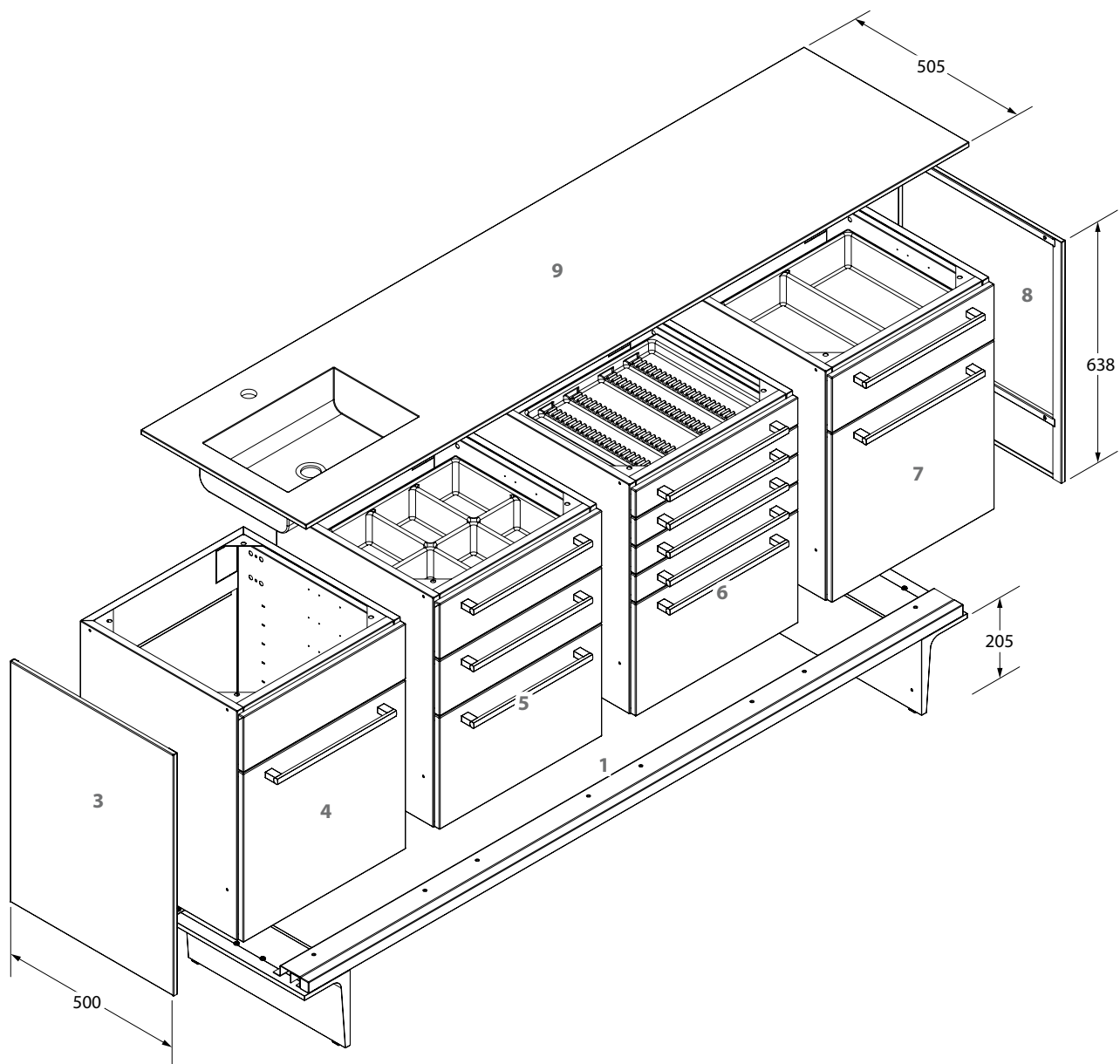

MOBILE VELA

- 1** Supporto a pavimento
- 2** Bordo di finitura per versione a muro
- 3** Fianco laterale
- 4** Mobile lavello
- 5** Mobile con 2 cassetti B + 1D
- 6** Mobile con 4 cassetti A + 1D
- 7** Mobile con 1 cassetto B + anta
- 8** Fianco terminale dx
- 9** Piano con lavello sx
- 10** Sistema di aggancio per versione a muro

H Sottopiano 843 mm

UNIT VELA

- 1** Floor support
- 2** Finish profile for wall support
- 3** Lateral side LH
- 4** Sink unit
- 5** Unit with 2 drawers B + 1 D
- 6** Unit with 4 drawers A + 1 D
- 7** Unit with 1 drawer B + door
- 8** Lateral side RH
- 9** Top with sink on the left side
- 10** Coupling system for wall support

H Under the top 843 mm

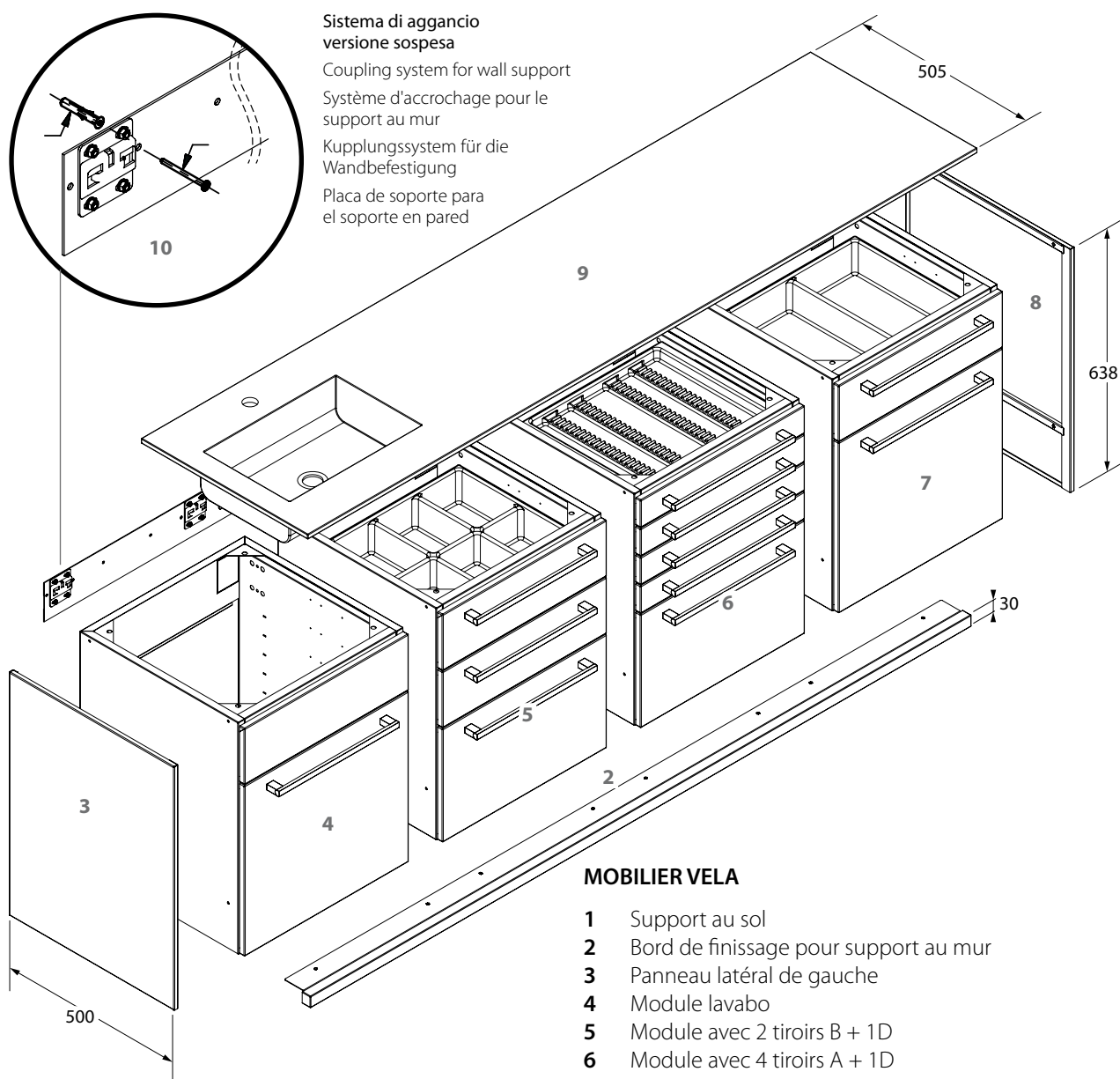

Sistema di aggancio versione sospesa

Coupling system for wall support

Système d'accrochage pour le support au mur

Kupplungssystem für die Wandbefestigung

Placa de soporte para el soporte en pared

MOBILIER VELA

- 1 Support au sol
- 2 Bord de finissage pour support au mur
- 3 Panneau latéral de gauche
- 4 Module lavabo
- 5 Module avec 2 tiroirs B + 1 D
- 6 Module avec 4 tiroirs A + 1 D
- 7 Module avec 1 tiroir B et porte
- 8 Panneau latéral de droite
- 9 Plan avec évier à gauche
- 10 Système d'accrochage pour le support au mur

H Sous plan de travail 843 mm

VELA-MÖBEL

- 1 Bodengestell
- 2 Abschlussleiste für die Wandbefestigung
- 3 Seitenwand links
- 4 Waschbeckenschrank
- 5 Schrank mit 2 Schubladen B und 1 D
- 6 Schrank mit 4 Schubladen A und 1 D
- 7 Schrank mit 1 Schublade B und Tür
- 8 Seitenwand rechts
- 9 Arbeitsplatte mit Waschbecken links
- 10 Kupplungssystem für die Wandbefestigung

H Unter der Arbeitsplatte 843 mm

MUEBLE VELA

- 1 Soporte de pie
- 2 Borde de acabado para soporte en pared
- 3 Panel lateral izq.
- 4 Módulo bajo lavabo
- 5 Módulo con 2 cajones B + 1 D
- 6 Módulo con 4 cajones A + 1 D
- 7 Módulo con 1 cajón B + puerta
- 8 Panel lateral dcho.
- 9 Encimera con lavabo izq.
- 10 Placa de soporte para el soporte en pared

A Bajo encimera 843 mm

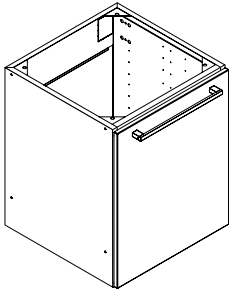
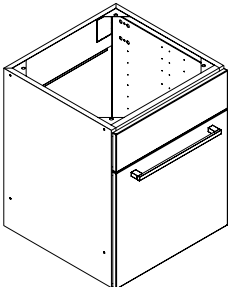
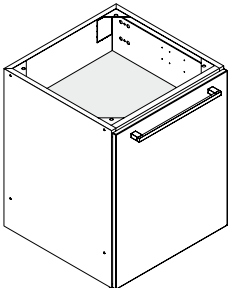
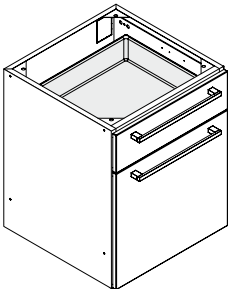
	Descrizione / Description Description / Beschreibung / Descripción	Apertura Opening / Ouverture Öffnung / Apertura	M³ Kg	Articolo Item / Article Artikel / Artículo
 <p>MODULO sottolavello con anta e portarifiuti interno Sink unit with door and rubbish bin Module lavabo avec porte et poubelle Waschbeckenschrank mit Tür und Abfalleimer Módulo lavabo con puerta y cubo de basura</p> <p>L 500 x P 498 x H 608 mm</p>		Maniglia Handle Poignée Griff Tirador	$\frac{0,25}{20,5}$	VLAM
		Push-Pull	$\frac{0,25}{20,3}$	VLAP
 <p>MODULO sottolavello con frontale fisso e anta "VLB" o con cassettone estraibile "VLC", con portarifiuti interno Sink unit with fixed front and door "VLB" or pullout drawer "VLC", with rubbish bin Module lavabo avec façade fixe et porte "VLB" ou grand tiroir extractible "VLC", avec poubelle Waschbeckenschrank mit fest Frontplatte und Tür "VLB" oder Schublade "VLC", mit Abfalleimer Módulo lavabo con frente fijo y puerta "VLB" o cajón "VLC", con cubo de basura</p> <p>L 500 x P 498 x H 608 mm</p>		Maniglia Handle Poignée Griff Tirador	$\frac{0,25}{21}$	VLBM
		Maniglia Handle Poignée Griff Tirador	$\frac{0,25}{25,5}$	VLCM
		Maniglia Handle Poignée Griff Tirador	$\frac{0,25}{20,8}$	VLBP
		Push-Pull	$\frac{0,25}{25,3}$	VLCP
 <p>MODULO con anta e due ripiani interni Unit with door and 2 interior shelves Module avec porte et 2 étagères internes Schränk mit Tür und 2 Einlegeböden Módulo con puerta y dos estantes interiores</p> <p>L 500 x P 498 x H 608 mm</p>		Maniglia Handle Poignée Griff Tirador	$\frac{0,25}{20,5}$	VPAM
		Push-Pull	$\frac{0,25}{20,3}$	VPAP
 <p>MODULO con cassetto B e anta con 1 ripiano interno Unit with drawer B and door with an interior shelf Module avec 1 tiroir B et porte avec 1 étagère à l'intérieur Schränk mit 1 Schublade B und Tür mit 1 Einlegeboden Módulo con cajón B y puerta con 1 estante interior</p> <p>L 500 x P 498 x H 608 mm</p>		Maniglia Handle Poignée Griff Tirador	$\frac{0,25}{25}$	VPBM
		Push-Pull	$\frac{0,25}{24,6}$	VPBP

Bacinelle / Trays / Intérieurs de tiroir
Einsätze / Cubetas: 1xVBB1

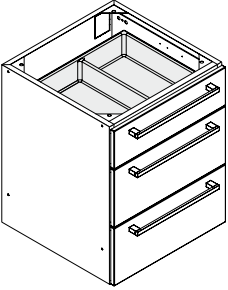
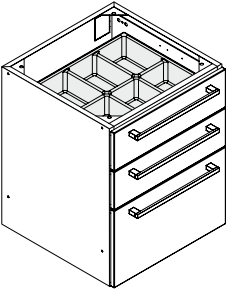
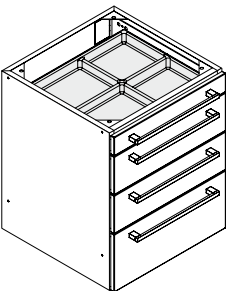
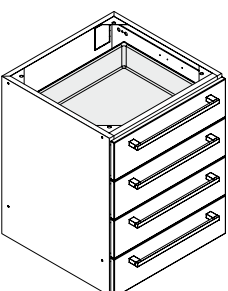
	Descrizione / Description Description / Beschreibung / Descripción	Apertura Opening / Ouverture Öffnung / Apertura	M³ Kg	Articolo Item / Article Artikel / Artículo
 <p>MODULO con 3 cassetti: 1 B e 2 C Unit with 3 drawers: 1 B and 2 C Module avec 3 tiroirs: 1 B et 2 C Schrank mit 3 Schubladen: 1 B und 2 C Módulo con 3 cajones: 1 B y 2 C</p> <p>Bacelle / Trays / Intérieurs de tiroir / Einsätze / Bandejas: 1xVBB2, 2xVBC1</p> <p>L 500 x P 498 x H 608 mm</p>		<p>Maniglia Handle Poignée Griff Tirador</p>	<p>0,25 ----- 35,2</p>	V3AM
		<p>Push-Pull</p>	<p>0,25 ----- 34,6</p>	V3AP
 <p>MODULO con 3 cassetti: 2 B e 1 D Unit with 3 drawers: 2 B and 1 D Module avec 3 tiroirs: 2 B et 1 D Schrank mit 3 Schubladen: 2 B und 1 D Módulo con 3 cajones: 2 B y 1 D</p> <p>Bacelle / Trays / Intérieurs de tiroir / Einsätze / Bandejas: 1xVBB2, 1xVBB4, 1xVBC1</p> <p>L 500 x P 498 x H 608 mm</p>		<p>Maniglia Handle Poignée Griff Tirador</p>	<p>0,25 ----- 35</p>	V3BM
		<p>Push-Pull</p>	<p>0,25 ----- 34,4</p>	V3BP
 <p>MODULO con 4 cassetti: 1 A, 2 B e 1 C Unit with 4 drawers: 1 A, 2 B and 1 C Module avec 4 tiroirs: 1 A, 2 B et 1 C Schrank mit 4 Schubladen: 1 A, 2 B und 1 C Módulo con 4 cajones: 1 A, 2B y 1 C</p> <p>Bacelle / Trays / Intérieurs de tiroir / Einsätze / Bandejas: 1xVBA3, 1xVBB1, 1xVBB2, 1xVBC1</p> <p>L 500 x P 498 x H 608 mm</p>		<p>Maniglia Handle Poignée Griff Tirador</p>	<p>0,25 ----- 40,2</p>	V4AM
		<p>Push-Pull</p>	<p>0,25 ----- 39,4</p>	V4AP
 <p>MODULO con 4 cassetti: 4 B Unit with 4 drawers: 4 B Module avec 4 tiroirs: 4 B Schrank mit 4 Schubladen: 4 B Módulo con 4 cajones: 4 B</p> <p>Bacelle / Trays / Intérieurs de tiroir / Einsätze / Bandejas: 1xVBB1, 1xVBB2, 1xVBB3, 1xVBB4</p> <p>L 500 x P 498 x H 608 mm</p>		<p>Maniglia Handle Poignée Griff Tirador</p>	<p>0,25 ----- 40,4</p>	V4BM
		<p>Push-Pull</p>	<p>0,25 ----- 39,6</p>	V4BP

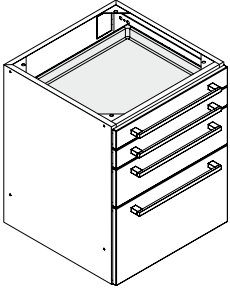
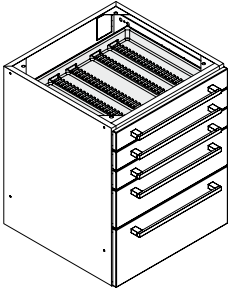
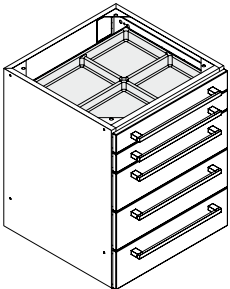
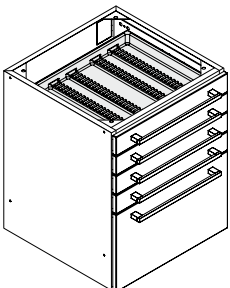
	Descrizione / Description Description / Beschreibung / Descripción	Apertura Opening / Ouverture Öffnung / Apertura	M³ Kg	Articolo Item / Article Artikel / Artículo
 <p>MODULO con 4 cassetti: 2 A, 1 B e 1 D Unit with 4 drawers: 2 A, 1 B and 1 D Module avec 4 tiroirs: 2 A, 1 B et 1 D Schrank mit 4 Schubladen: 2 A, 1 B und 1 D Módulo con 4 cajones: 2 A, 1 B y 1 D</p> <p>Bacinelle / Trays / Intérieurs de tiroir / Einsätze / Bandejas: 1xVBA2, 1xVBA4, 1xVBB4, 1xVBC1</p> <p>L 500 x P 498 x H 608 mm</p>		Maniglia Handle Poignée Griff Tirador	0,25 ----- 39,8	V4CM
		Push-Pull	0,25 ----- 39	V4CP
 <p>MODULO con 5 cassetti: 3 A, 1 B e 1 C Unit with 5 drawers: 3 A, 1 B and 1 C Module avec 5 tiroirs: 3 A, 1 B et 1 C Schrank mit 5 Schubladen: 3 A, 1 B und 1 C Módulo con 5 cajones: 3 A, 1 B y 1 C</p> <p>Bacinelle / Trays / Intérieurs de tiroir / Einsätze / Bandejas: 1xVBA1, 1xVBA3, 1xVBA4, 1xVBB1, 1xVBC1</p> <p>L 500 x P 498 x H 608 mm</p>		Maniglia Handle Poignée Griff Tirador	0,25 ----- 45	V5AM
		Push-Pull	0,25 ----- 44	V5AP
 <p>MODULO con 5 cassetti: 2 A e 3 B Unit with 5 drawers: 2 A and 3 B Module avec 5 tiroirs: 2 A et 3 B Schrank mit 5 Schubladen: 2 A und 3 B Módulo con 5 cajones: 2 A y 3 B</p> <p>Bacinelle / Trays / Intérieurs de tiroir / Einsätze / Bandejas: 1xVBA3, 1xVBA4, 1xVBB1, 1xVBB2, 1xVBB4</p> <p>L 500 x P 498 x H 608 mm</p>		Maniglia Handle Poignée Griff Tirador	0,25 ----- 45,2	V5BM
		Push-Pull	0,25 ----- 44,2	V5BP
 <p>MODULO con 5 cassetti: 4 A e 1 D Unit with 5 drawers: 4 A and 1 D Module avec 5 tiroirs: 4 A et 1 D Schrank mit 5 Schubladen: 4 A und 1 D Módulo con 5 cajones: 4 A y 1 D</p> <p>Bacinelle / Trays / Intérieurs de tiroir / Einsätze / Bandejas: 1xVBA1, 1xVBA2, 1xVBA3, 1xVBA4, 1xVBC1</p> <p>L 500 x P 498 x H 608 mm</p>		Maniglia Handle Poignée Griff Tirador	0,25 ----- 44,6	V5CM
		Push-Pull	0,25 ----- 43,6	V5CP

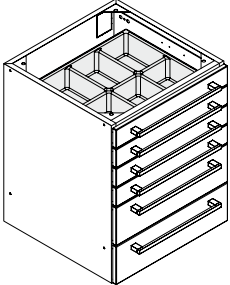
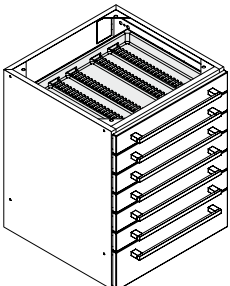
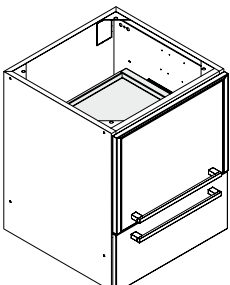
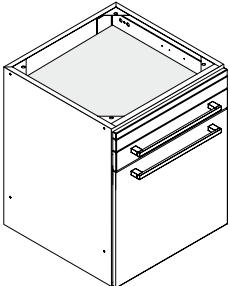
	Descrizione / Description Description / Beschreibung / Descripción	Apertura Opening / Ouverture Öffnung / Apertura	M ³ Kg	Articolo Item / Article Artikel / Artículo
 <p>MODULO con 6 cassetti: 4 A e 2 B Unit with 6 drawers: 4 A and 2 B Module avec 6 tiroirs: 4 A et 2 B Schrank mit 6 Schubladen: 4 A und 2 B Módulo con 6 cajones: 4 A y 2 B</p> <p>Bacelle / Trays / Intérieurs de tiroir / Einsätze / Bandejas: 1xVBA1, 1xVBA2, 1xVBA3, 1xVBA4, 1xVBB1, 1xVBB4</p> <p>L 500 x P 498 x H 608 mm</p>		<p>Maniglia Handle Poignée Griff Tirador</p>	<p>0,25 50</p>	V6AM
		<p>Push-Pull</p>	<p>0,25 48,8</p>	V6AP
 <p>MODULO con 7 cassetti: 6 A e 1 B Unit with 7 drawers: 6 A and 1 B Module avec 7 tiroirs: 6 A et 1 B Schrank mit 7 Schubladen: 6 A et 1 B Módulo con 7 cajones: 6 A y 1 B</p> <p>Bacelle / Trays / Intérieurs de tiroir / Einsätze / Bandejas: 1xVBA1, 2xVBA2, 2xVBA3, 1xVBA4, 1xVBB3</p> <p>L 500 x P 498 x H 608 mm</p>		<p>Maniglia Handle Poignée Griff Tirador</p>	<p>0,25 54,8</p>	V7AM
		<p>Push-Pull</p>	<p>0,25 53,4</p>	V7AP
 <p>MODULO con anta a ribalta con 2 ripiani estraibili per apparecchiature + ciabatta con 4 prese di corrente e cassetto C Unit with hide-away door equipped with 2 apparatus storage shelves + 4 Schuko sockets and 1 drawer C Module avec porte basculante avec 2 tiroirs pour appareils + 4 prises de courant Schuko et 1 tiroir C Schrank mit versenkbarer Tür mit 2 Geräteeinlagen + 4 Schuko-Steckdosen und 1 Schublade C Módulo con puerta plegable con 2 estantes extraíbles para equipos + regleta con 4 tomas de corriente Schuko y cajón C</p> <p>L 500 x P 498 x H 608 mm</p>		<p>Maniglia Handle Poignée Griff Tirador</p>	<p>0,25 33</p>	VRAM
		<p>Push-Pull</p>	<p>0,25 32,6</p>	VRAP
 <p>MODULO PC con cassetto A per tastiera (L 385 - H 30 mm max), 1 cassetto A e anta, con schiena aperta Unit for PC with 1 drawer A for keyboard (L - H), 1 drawer A and door, open back Module pour PC avec 1 tiroir A pour clavier (L - H), 1 tiroir A et porte, ouvert derrière Schrank für PC mit 1 Schublade A für Tastatur (L - H), 1 Schublade A und Tür, Rückwand geöffnet Módulo PC con 1 cajón A porta teclado (L - H), 1 cajón A y puerta, con panel trasero abierto</p> <p>L 500 x P 498 x H 608 mm</p>		<p>Maniglia Handle Poignée Griff Tirador</p>	<p>0,25 25</p>	VPCM
		<p>Push-Pull</p>	<p>0,25 24,8</p>	VPCP

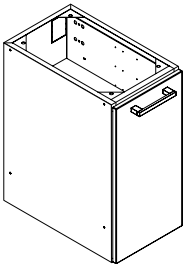
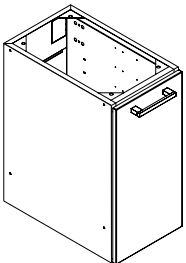
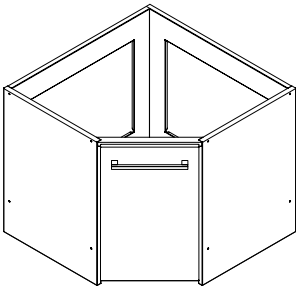
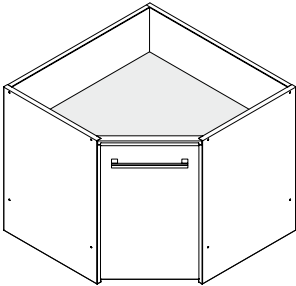
	Descrizione / Description Description / Beschreibung / Descripción	Apertura Opening / Ouverture Öffnung / Apertura	M ³ Kg	Articolo Item / Article Artikel / Artículo
 <p>MODULO con anta e due ripiani interni Unit with door and 2 interior shelves Module avec porte et 2 étagères internes Schrank mit Tür und 2 Einlegeböden Módulo con puerta y dos estantes interiores</p> <p>L 300/400 x P 498 x H 608 mm</p>		Maniglia Handle Poignée Griff Tirador	0,25 ----- 16	VPDM (L. 300 mm)
		Push-Pull	0,25 ----- 17	VPGM (L. 400 mm)
			0,25 ----- 15,9	VPDP (L. 300 mm)
			0,25 ----- 16,9	VPGP (L. 400 mm)
 <p>MODULO con anta e due ripiani interni, con schiena aperta Unit with door and 2 interior shelves, open back Module avec porte et 2 étagères internes, ouvert derrière Schrank mit Tür und 2 Einlegeböden, Rückwand geöffnet Módulo con puerta y dos estantes interiores, con panel trasero abierto</p> <p>L 300 x P 498 x H 608 mm</p>		Maniglia Handle Poignée Griff Tirador	0,25 ----- 15,5	VPEM
		Push-Pull	0,23 ----- 15,4	VPEP
 <p>MODULO angolare sottolavello con anta e portarifiuti interno Corner sink unit with door and rubbish bin Module lavabo d'angle avec porte et poubelle Eckwaschbeckenschrank mit Tür und Abfalleimer Módulo angular lavabo con puerta y cubo de basura</p> <p>L 750 x P 750 x H 608 mm</p>		Maniglia Handle Poignée Griff Tirador	0,70 ----- 17,5	VAAM
		Push-Pull	0,70 ----- 17,4	VAAP
 <p>MODULO angolare con anta e 1 ripiano interno Corner unit with door and 1 interior shelf Module d'angle avec porte et 1 étagère interne Eckschrank mit Tür und 1 Einlegeboden Módulo angular con puerta y estante interior</p> <p>L 750 x P 750 x H 608 mm</p>		Maniglia Handle Poignée Griff Tirador	0,70 ----- 22	VACM
		Push-Pull	0,70 ----- 21,9	VACP

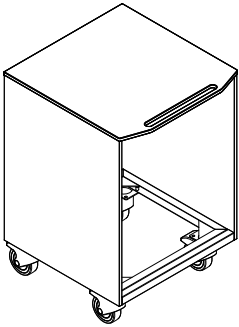
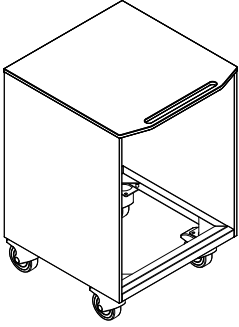
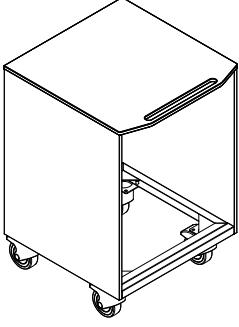
	Descrizione / Description Description / Beschreibung / Descripción	Fianchi Sides / Côtés Seiten / Laterales	M³ Kg	Articolo Item / Article Artikel / Artículo
 <p>Kit ruote + piano sagomato in Corian® bianco Castor set + shaped white Corian® top Kit roues + plan façonné en Corian® blanc Rollenset + Arbeitsplatte aus geformtem weißem Corian® Kit de ruedas + encimera perfilada de Corian® blanco</p> <p>L 528 x P 555 x H 787 mm</p>		Verniciato Painted / Verni Lackiert Pintado	0,08 ----- 21	KRCV
		Stratificato Stratified / Stratifié Schichtstoff Estratificado	0,08 ----- 26,4	KRCS
		Corian®	0,08 ----- 28	KRCC
 <p>Kit ruote + piano sagomato in stratificato bianco Castor set + shaped white stratified top Kit roues + plan façonné en stratifié blanc Rollenset + Arbeitsplatte aus geformtem weißem Schichtstoff Kit de ruedas + encimera perfilada de estratificado blanco</p> <p>L 528 x P 555 x H 787 mm</p>		Verniciato Painted / Verni Lackiert Pintado	0,08 ----- 20,3	KRSV
		Stratificato Stratified / Stratifié Schichtstoff Estratificado	0,08 ----- 25,7	KRSS
		Corian®	0,08 ----- 27,3	KRSC
 <p>Kit ruote + piano sagomato in vetro Castor set + shaped glass top Kit roues + plan façonné en verre Rollenset + geformte Glasarbeitsplatte Kit de ruedas + encimera perfilada de vidrio</p> <p>L 528 x P 555 x H 790 mm</p>		Verniciato Painted / Verni Lackiert Pintado	0,08 ----- 25,6	KRWV
		Stratificato Stratified / Stratifié Schichtstoff Estratificado	0,08 ----- 31	KRVS
		Corian®	0,08 ----- 32,6	KRVC
	MAGGIORAZIONI per piano in vetro Additional charge for glass top Supplément de prix pour plan en verre Aufpreis für Glasarbeitsplatte Cargo adicional para encimera de vidrio	Extra-chiaro Extra clear Transparent Transparent Transparente		
		Satinato Satin / Dépoli Satinier Satinado		

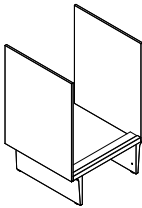
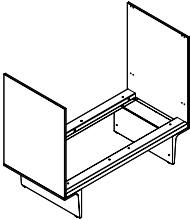
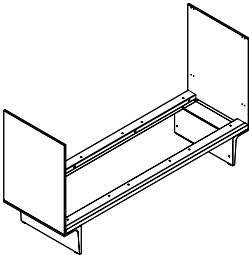
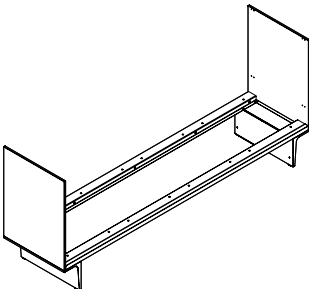
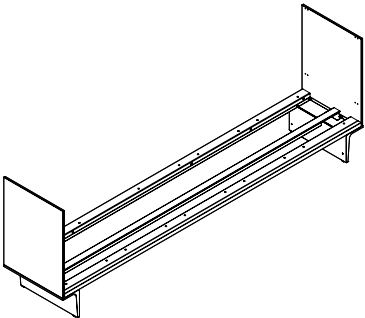
	Descrizione / Description Description / Beschreibung / Descripción	Fianchi Sides / Côtés Seiten / Laterales	M³ Kg	Articolo Item / Article Artikel / Artículo
 L 528 mm	SUPPORTO a pavimento per 1 modulo Floor support for 1 unit Support au sol pour 1 module Bodengestell für 1 Schrank Soporte de pie para 1 módulo	Verniciato Painted / Verni Lackiert Pintado	0,14 <hr/> 26	VS1V
		Stratificato Stratified / Stratifié Schichtstoff Estratificado	0,14 <hr/> 31	VS1S
		Corian®	0,14 <hr/> 33	VS1C
 L 1028 mm	SUPPORTO a pavimento per 2 moduli Floor support for 2 units Support au sol pour 2 modules Bodengestell für 2 Schränke Soporte de pie para 2 módulos	Verniciato Painted / Verni Lackiert Pintado	0,26 <hr/> 34	VS2V
		Stratificato Stratified / Stratifié Schichtstoff Estratificado	0,26 <hr/> 39	VS2S
		Corian®	0,26 <hr/> 41	VS2C
 L 1528 mm	SUPPORTO a pavimento per 3 moduli Floor support for 3 units Support au sol pour 3 modules Bodengestell für 3 Schränke Soporte de pie para 3 módulos	Verniciato Painted / Verni Lackiert Pintado	0,35 <hr/> 38	VS3V
		Stratificato Stratified / Stratifié Schichtstoff Estratificado	0,35 <hr/> 43	VS3S
		Corian®	0,35 <hr/> 45	VS3C
 L 2028 mm	SUPPORTO a pavimento per 4 moduli Floor support for 4 units Support au sol pour 4 modules Bodengestell für 4 Schränke Soporte de pie para 4 módulos	Verniciato Painted / Verni Lackiert Pintado	0,40 <hr/> 42	VS4V
		Stratificato Stratified / Stratifié Schichtstoff Estratificado	0,40 <hr/> 47	VS4S
		Corian®	0,40 <hr/> 49	VS4C
 L 2528 mm	SUPPORTO a pavimento per 5 moduli Floor support for 5 units Support au sol pour 5 modules Bodengestell für 5 Schränke Soporte de pie para 5 módulos	Verniciato Painted / Verni Lackiert Pintado	0,54 <hr/> 57	VS5V
		Stratificato Stratified / Stratifié Schichtstoff Estratificado	0,54 <hr/> 62	VS5S
		Corian®	0,54 <hr/> 64	VS5C

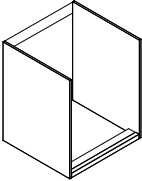
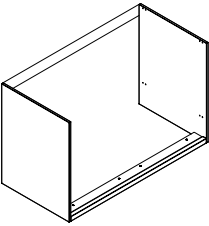
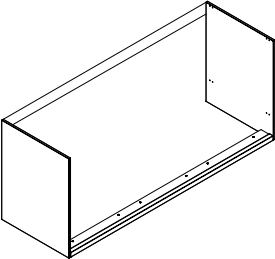
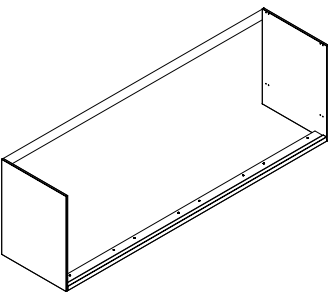
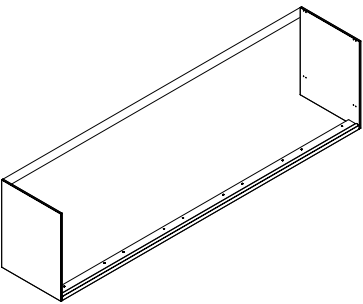
	Descrizione / Description Description / Beschreibung / Descripción	Fianchi Sides / Côtés Seiten / Laterales	M³ Kg	Articolo Item / Article Artikel / Artículo
 L 528 mm	SUPPORTO a muro per 1 modulo Wall support for 1 unit Support au mur pour 1 module Wandbefestigung für 1 Schrank Soporte de pared para 1 módulo	Verniciato Painted / Verni Lackiert Pintado	$\frac{0,01}{10}$	VM1V
		Stratificato Stratified / Stratifié Schichtstoff Estratificado	$\frac{0,01}{15}$	VM1S
		Corian®	$\frac{0,01}{17}$	VM1C
 L 1028 mm	SUPPORTO a muro per 2 moduli Wall support for 2 units Support au mur pour 2 modules Wandbefestigung für 2 Schränke Soporte de pared para 2 módulos	Verniciato Painted / Verni Lackiert Pintado	$\frac{0,02}{12,5}$	VM2V
		Stratificato Stratified / Stratifié Schichtstoff Estratificado	$\frac{0,02}{17,5}$	VM2S
		Corian®	$\frac{0,02}{19,5}$	VM2C
 L 1528 mm	SUPPORTO a muro per 3 moduli Wall support for 3 units Support au mur pour 3 modules Wandbefestigung für 3 Schränke Soporte de pared para 3 módulos	Verniciato Painted / Verni Lackiert Pintado	$\frac{0,03}{14,5}$	VM3V
		Stratificato Stratified / Stratifié Schichtstoff Estratificado	$\frac{0,03}{19,5}$	VM3S
		Corian®	$\frac{0,03}{21,5}$	VM3C
 L 2028 mm	SUPPORTO a muro per 4 moduli Wall support for 4 units Support au mur pour 4 modules Wandbefestigung für 4 Schränke Soporte de pared para 4 módulos	Verniciato Painted / Verni Lackiert Pintado	$\frac{0,04}{17}$	VM4V
		Stratificato Stratified / Stratifié Schichtstoff Estratificado	$\frac{0,04}{22}$	VM4S
		Corian®	$\frac{0,04}{24}$	VM4C
 L 2528 mm	SUPPORTO a muro per 5 moduli Wall support for 5 units Support au mur pour 5 modules Wandbefestigung für 5 Schränke Soporte de pared para 5 módulos	Verniciato Painted / Verni Lackiert Pintado	$\frac{0,05}{21}$	VM5V
		Stratificato Stratified / Stratifié Schichtstoff Estratificado	$\frac{0,05}{26}$	VM5S
		Corian®	$\frac{0,05}{28}$	VM5C

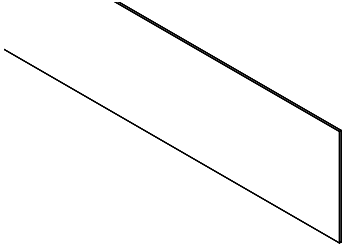
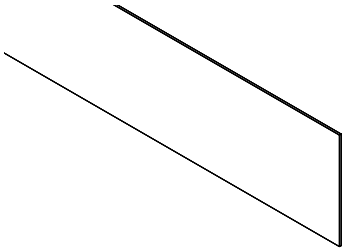
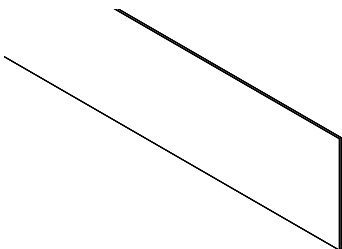
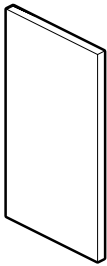
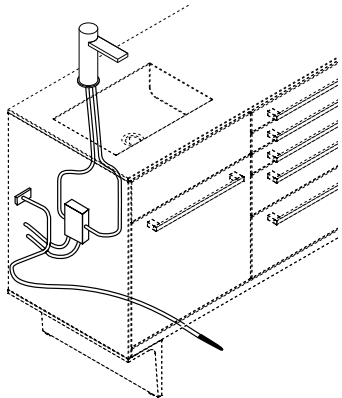
	Descrizione / Description Description / Beschreibung / Descripción	M³ Kg	Articolo Item / Article Artikel / Artículo
 <p>P 12 x H 638 mm</p>	<p>Tamponamento posteriore verniciato: al metro lineare</p> <p>Painted closing back panel: per meter Cache de fermeture à l'arrière, verni: au mètre Lackierte Verschlußverkleidung: je Meter Panel trasero, pintado: al m.</p>	- 5	TV
 <p>P 12 x H 638 mm</p>	<p>Tamponamento posteriore in stratificato: al metro lineare</p> <p>Stratified closing back panel: per meter Cache de fermeture à l'arrière, en stratifié: au mètre Verschlußverkleidung aus Schichtstoff: je Meter Panel trasero, de estratificado: al m.</p>	- 8	TS
 <p>P 12 x H 638 mm</p>	<p>Tamponamento posteriore in Corian®: al metro lineare</p> <p>Corian® closing back panel: per meter Cache de fermeture à l'arrière, en Corian®: au mètre Verschlußverkleidung aus Corian®: je Meter Panel trasero, de Corian®: al m.</p>	- 10	TC
 <p>L 30 x P 480 x H 843 mm</p>	<p>Pannello laterale verniciato di sostegno piano</p> <p>Painted top-support side panel Panneau latéral verni, de support pour le plan Lackierte Abschlußverkleidung Panel lateral pintado para el soporte de la encimera</p>	- 8	VSL5
	<p>Kit comando elettromagnetico 24V ad asta</p> <p>24V electromagnetic control kit Kit commande électromagnétique 24V pour l'eau Elektromagnetischer Wasserauslöser 24V Kit de control electromagnético 24V</p>	- 1	VKEL

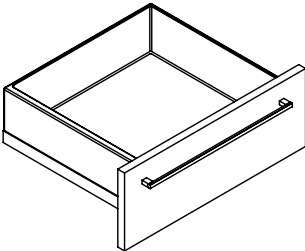
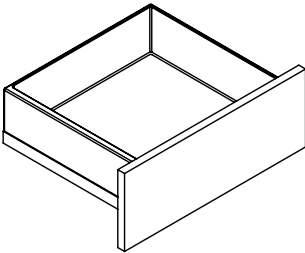
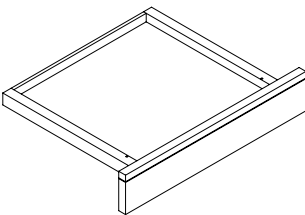
	Descrizione / Description Description / Beschreibung / Descripción		M³ Kg	Articolo Item / Article Artikel / Artículo
	CASSETTO con maniglia Drawer with handle Tiroir avec poignée Schublade mit Griff Cajón con tirador	A) H 75	- 5,7	VCAAM
		B) H 150	- 6,6	VCABM
		C) H 225	- 7,3	VCACM
		D) H 300	- 7,8	VCADM
	CASSETTO Push-Pull Drawer Push-Pull Tiroir Push-Pull Schublade Push-Pull Cajón Push-Pull	A) H 75	- 5,5	VCAAP
		B) H 150	- 6,4	VCABP
		C) H 225	- 7,1	VCACP
		D) H 300	- 7,6	VCADP
	CASSETTO per tastiera (L 385 - H 30 mm max) Drawer for keyboard (L 385 - H 30 mm) Tiroir pour clavier (L 385 - H 30 mm) Schublade für Tastatur (L 385 - H 30 mm) Cajón porta teclado (L 385 - H 30 mm)	A) H 75	- 5,5	VCAAPK

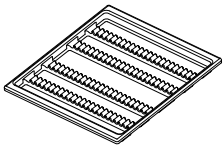
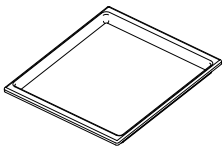
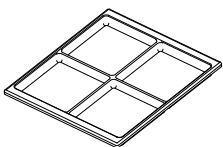
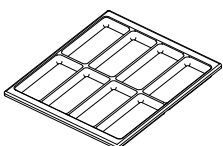
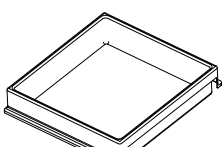
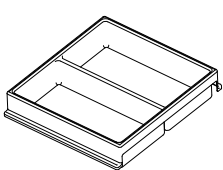
	Descrizione / Description Description / Beschreibung / Descripción	M³ Kg	Articolo Item / Article Artikel / Artículo
	BACINELLA con rastrelliera portastrumenti, per cassetto A Instrument compartment drawer tray, for drawer A Intérieur de tiroir porte-instruments, pour tiroir A Einsatz mit Instrumentenhalter, für Schublade A Bandeja porta instrumentos, para cajón A	- 0,5	VBA1
	BACINELLA piana, per cassetto A Flat drawer tray, for drawer A Intérieur de tiroir bas, pour tiroir A Niedriger Einsatz, für Schublade A Bandeja plana, para cajón A	- 0,5	VBA2
	BACINELLA a 4 settori, per cassetto A Drawer tray with 4 compartments, for drawer A Intérieur de tiroir à 4 secteurs, pour tiroir A 4-Fächern Einsatz, für Schublade A Bandeja con 4 sectores, para cajón A	- 0,5	VBA3
	BACINELLA a 8 settori, per cassetto A Drawer tray with 8 compartments, for drawer A Intérieur de tiroir à 8 secteurs, pour tiroir A 8-Fächern Einsatz, für Schublade A Bandeja con 8 sectores, para cajón A	- 0,5	VBA4
	BACINELLA piana, per cassetto B Flat drawer tray, for drawer B Intérieur de tiroir bas, pour tiroir B Niedriger Einsatz, für Schublade B Bandeja plana, para cajón B	- 0,9	VBB1
	BACINELLA a 2 settori, per cassetto B Drawer tray with 2 compartment, for drawer B Intérieur de tiroir à 2 secteurs, pour tiroir B 2-Fächern Einsatz, für Schublade B Bandeja con 2 sectores, para cajón B	- 0,9	VBB2

L 440 x P 389 x H 31 mm

L 440 x P 389 x H 31 mm

L 440 x P 389 x H 31 mm

L 440 x P 389 x H 31 mm

L 400 x P 389 x H 90 mm

L 400 x P 389 x H 90 mm

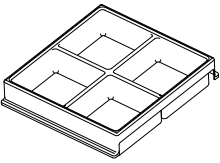
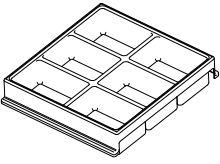
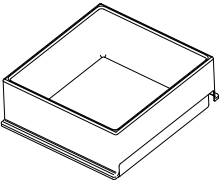
	Descrizione / Description Description / Beschreibung / Descripción	M³ Kg	Articolo Item / Article Artikel / Artículo
 <p>L 400 x P 389 x H 90 mm</p>	<p>BACINELLA a 4 settori, per cassetto B Drawer tray with 4 compartments, for drawer B Intérieur de tiroir à 4 secteurs, pour tiroir B 4-Fächern Einsatz, für Schublade B Bandeja con 4 sectores, para cajón B</p>	<p>- 0,9</p>	VBB3
 <p>L 400 x P 389 x H 90 mm</p>	<p>BACINELLA a 6 settori, per cassetto B Drawer tray with 6 compartments, for drawer B Intérieur de tiroir à 6 secteurs, pour tiroir B 6-Fächern Einsatz, für Schublade B Bandeja con 6 sectores, para cajón B</p>	<p>- 0,9</p>	VBB4
 <p>L 400 x P 389 x H 165 mm</p>	<p>BACINELLA piana, per cassetti C e D Flat drawer tray, for drawers C and D Intérieur de tiroir bas, pour tiroirs C et D Niedriger Einsatz, für Schubladen C und D Bandeja plana, para cajones C y D</p>	<p>- 1,1</p>	VBC1

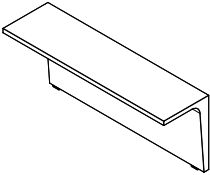
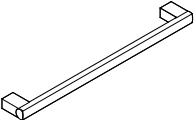
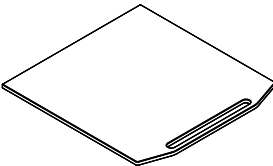
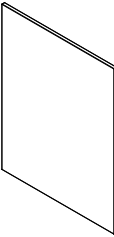
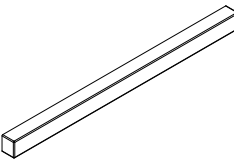
	Descrizione / Description Description / Beschreibung / Descripción		M³ Kg	Articolo Item / Article Artikel / Artículo
	PIEDE in alluminio Aluminium foot Pied en aluminium Aluminiumfuß Pata de aluminio	DX / RH Droite / Rechts Dcho	- 8	VPAD
		SX / LH Gauche / Links Izq	- 8	VPAS
	MANIGLIA in alluminio per "Vela" Aluminium handle for "Vela" Poignée en aluminium pour "Vela" Griff aus Aluminium für "Vela" Tirador de aluminio para "Vela"		- 0,4	MA010
	PIANO sagomato per servomobile Shaped top for movable unit Plan façonné pour module mobile Geformte Arbeitsplatte für Rollenschrank Encimera perfilada para módulo móvil	Stratificato Stratified / Stratifié Schichtstoff Estratificado	- 5,5	VPSS
		Corian®	- 6,2	VPSC
		Vetro / Glass Verre / Glas / Vidrio	- 10,8	VPSV
		Extra-chiaro Extra clear Transparent Transparent Extra-claro		
		Satinato / Satin Dépoli / Satiniert Satinado		
	FIANCO laterale Lateral side Panneau latéral Seitenwand Panel lateral	Verniciato Painted / Verni Lackiert / Pintado	- 3,5	VFV
		Stratificato Stratified / Stratifié Schichtstoff Estratificado	- 6,1	VFS
		Corian®	- 6,9	VFC
	BORDO di finitura (ogni modulo) Finish profile (each unit) Bord de finissage (chaque module) Abschlussleiste (jedes Schrank) Borde de acabado (cada módulo)	Verniciato Painted / Verni Lackiert / Pintado	- 0,7	BPV05
		Stratificato Stratified / Stratifié Schichtstoff Estratificado	- - -	BPS05
		Corian®	- -	BPC05

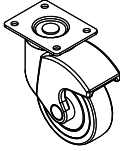
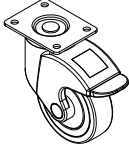
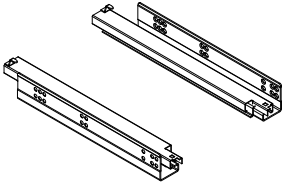
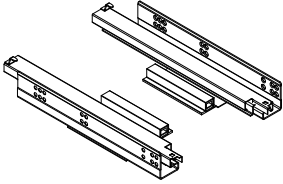
	Descrizione / Description Description / Beschreibung / Descripción	M³ Kg	Articolo Item / Article Artikel / Artículo
	<p>RUOTA senza freno Castor without brake Roue sans frein Rad ohne Bremse Rueda sin freno</p>	<p>- ----- 0,6</p>	<p>RUO15</p>
	<p>RUOTA con freno Castor with brake Roue avec frein Rad mit Bremse Rueda con freno</p>	<p>- ----- 0,7</p>	<p>RUO16</p>
	<p>COPPIA DI GUIDE con rientro ammortizzato Pair of guides with soft closing Couple de glissières avec amortisseur Eine Paar Führungen mit Softeinzug Par de guías con cierre suave</p>	<p>- ----- 1,7</p>	<p>GUI23</p>
	<p>COPPIA DI GUIDE per cassetto Push-Pull Pair of guides for Push-Pull drawer Couple de glissières pour tiroir Push-Pull Eine Paar Führungen für Push-Pull Schublade Par de guías para cajón Push-Pull</p>	<p>- ----- 1,9</p>	<p>GUI24</p>

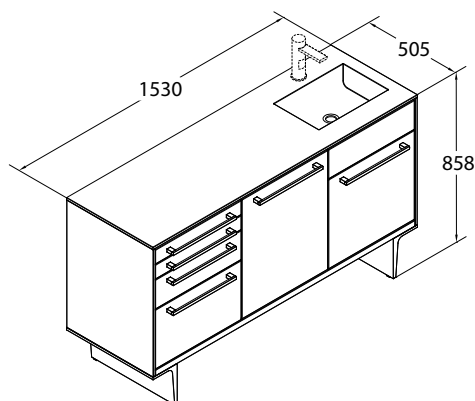

1	Piano in stratificato e fianchi verniciati Stratified top and painted sides / Plan stratifié et panneaux latéraux vernis / Arbeitsplatte aus Schichtstoff und lackierte Seitenwände / Encimera de estratificado y laterales pintados	+ VFA
2	Piano in vetro e fianchi verniciati Glass top and painted sides / Plan en verre et côtés peints / Arbeitsplatte aus Glas und lackierte Seitenwände / Encimera de vidrio y laterales pintados	+ VIV
3	Piano in Corian® e fianchi verniciati Corian® top and painted sides / Plan en Corian® et panneaux latéraux vernis / Arbeitsplatte aus Corian® und lackierte Seitenwände / Encimera de Corian® y laterales pintados	+ VIC
4	Piano e fianchi in Corian® Corian® top and Corian® sides / Plan et panneau latéraux en Corian® / Arbeitsplatte und Seitenwände aus Corian® / Encimera y laterales de Corian®	+ VIC

A **Composizione / Composition**
Composition / Zusammenstellung / Composición

V4C + VPA + VLB

La composizione è comprensiva di bacinelle standard. Rubinetto escluso.

Trays included. Mixer excluded

Intérieurs de tiroirs inclus. Robinet pas compris.

Standard Schubladeneinsätze sind enthalten. Armatur ist ausgeschlossen.

La composición incluye bandejas estándar. Grifo excluido.

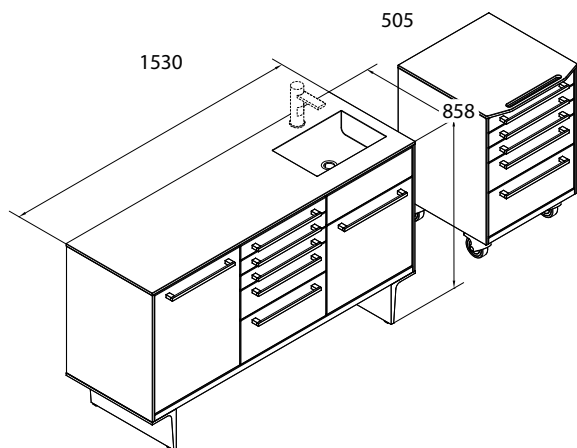

1	Piano in stratificato e fianchi verniciati Stratified top and painted sides / Plan stratifié et panneaux latéraux vernis / Arbeitsplatte aus Schichtstoff und lackierte Seitenwände / Encimera de estratificado y laterales pintados	+ VFA
2	Piano in vetro e fianchi verniciati Glass top and painted sides / Plan en verre et côtés peints / Arbeitsplatte aus Glas und lackierte Seitenwände / Encimera de vidrio y laterales pintados	+ VIV
3	Piano in Corian® e fianchi verniciati Corian® top and painted sides / Plan en Corian® et panneaux latéraux vernis / Arbeitsplatte aus Corian® und lackierte Seitenwände / Encimera de Corian® y laterales pintados	+ VIC
4	Piano e fianchi in Corian® Corian® top and Corian® sides / Plan et panneau latéraux en Corian® / Arbeitsplatte und Seitenwände aus Corian® / Encimera y laterales de Corian®	+ VIC

B **Composizione / Composition**
Composition / Zusammenstellung / Composición

VPA + V5A + VLB + V5A + KR

La composizione è comprensiva di bacinelle standard. Rubinetto escluso.

Trays included. Mixer excluded

Intérieurs de tiroirs inclus. Robinet pas compris.

Standard Schubladeneinsätze sind enthalten. Armatur ist ausgeschlossen.

La composición incluye bandejas estándar. Grifo excluido.

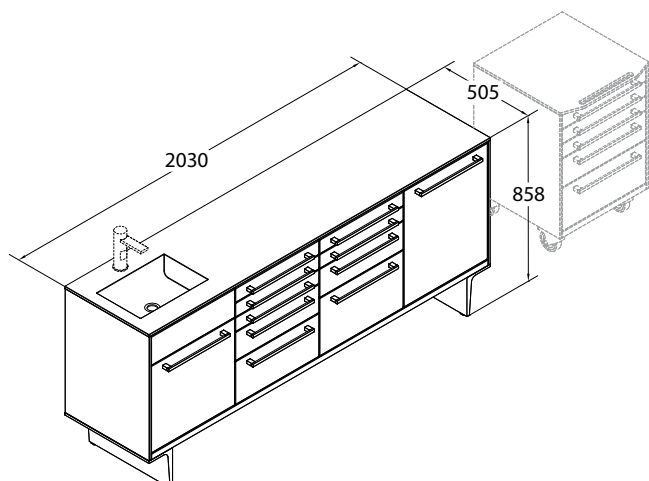

- | | |
|---|--|
| 1 | Piano in stratificato e fianchi verniciati
Stratified top and painted sides / Plan stratifié et panneaux latéraux vernis /
Arbeitsplatte aus Schichtstoff und lackierte Seitenwände / + VFA
Encimera de estratificado y laterales pintados |
| 2 | Piano in vetro e fianchi verniciati
Glass top and painted sides / Plan en verre et côtés peints /
Arbeitsplatte aus Glas und lackierte Seitenwände / + VIV
Encimera de vidrio y laterales pintados |
| 3 | Piano in Corian® e fianchi verniciati
Corian® top and painted sides / Plan en Corian® et panneaux latéraux vernis /
Arbeitsplatte aus Corian® und lackierte Seitenwände / + VIC
Encimera de Corian® y laterales pintados |
| 4 | Piano e fianchi in Corian®
Corian® top and Corian® sides / Plan et panneau latéraux en Corian® /
Arbeitsplatte und Seitenwände aus Corian® / + VIC
Encimera y laterales de Corian® |

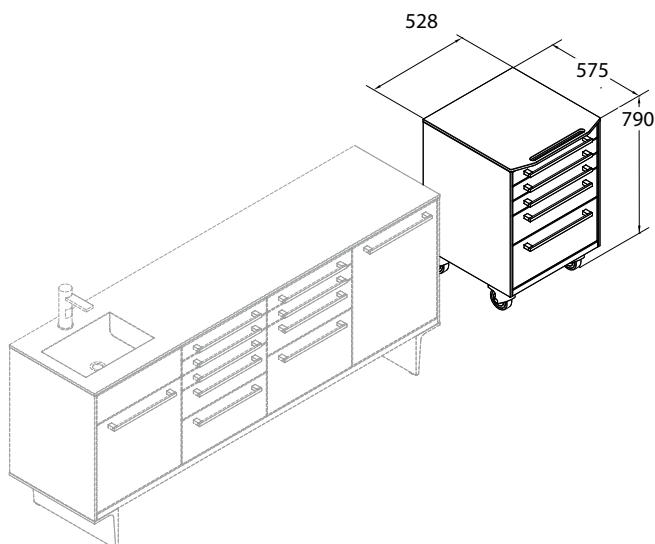

- | | |
|---|--|
| 1 | Piano in stratificato e fianchi verniciati
Stratified top and painted sides / Plan stratifié et panneaux latéraux vernis /
Arbeitsplatte aus Schichtstoff und lackierte Seitenwände /
Encimera de estratificado y laterales pintados |
| 2 | Piano in vetro e fianchi verniciati
Glass top and painted sides / Plan en verre et côtés peints /
Arbeitsplatte aus Glas und lackierte Seitenwände /
Encimera de vidrio y laterales pintados |
| 3 | Piano in Corian® e fianchi verniciati
Corian® top and painted sides / Plan en Corian® et panneaux latéraux vernis /
Arbeitsplatte aus Corian® und lackierte Seitenwände /
Encimera de Corian® y laterales pintados |
| 4 | Piano e fianchi in Corian®
Corian® top and Corian® sides / Plan et panneau latéraux en Corian® /
Arbeitsplatte und Seitenwände aus Corian® /
Encimera y laterales de Corian® |

C **Composizione** / Composition
Composition / Zusammenstellung / Composición

VLB + V5A + V4C + VPA

La composizione è comprensiva di bacinelle standard. Rubinetto escluso.

Trays included. Mixer excluded

Intérieurs de tiroirs inclus. Robinet pas compris.

Standard Schubladeneinsätze sind enthalten. Armatur ist ausgeschlossen.

La composición incluye bandejas estándar. Grifo excluido.

C **Servomobile** / Composition
Composition / Zusammenstellung / Composición

V5A + KR

Il servomobile è comprensivo di bacinelle standard.

Trays included.

Intérieurs de tiroirs inclus.

Standard Schubladeneinsätze sind enthalten.

La composición incluye bandejas estándar.

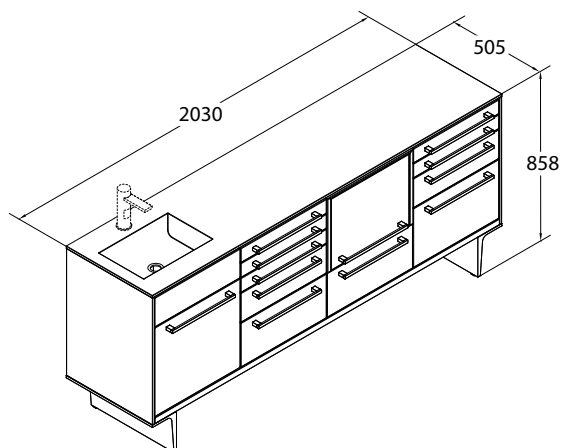

1	Piano in stratificato e fianchi verniciati Stratified top and painted sides / Plan stratifié et panneaux latéraux vernis / Arbeitsplatte aus Schichtstoff und lackierte Seitenwände / + VFA Encimera de estratificado y laterales pintados
2	Piano in vetro e fianchi verniciati Glass top and painted sides / Plan en verre et côtés peints / Arbeitsplatte aus Glas und lackierte Seitenwände / + VIV Encimera de vidrio y laterales pintados
3	Piano in Corian® e fianchi verniciati Corian® top and painted sides / Plan en Corian® et panneaux latéraux vernis / Arbeitsplatte aus Corian® und lackierte Seitenwände / + VIC Encimera de Corian® y laterales pintados
4	Piano e fianchi in Corian® Corian® top and Corian® sides / Plan et panneau latéraux en Corian® / Arbeitsplatte und Seitenwände aus Corian® / + VIC Encimera y laterales de Corian®

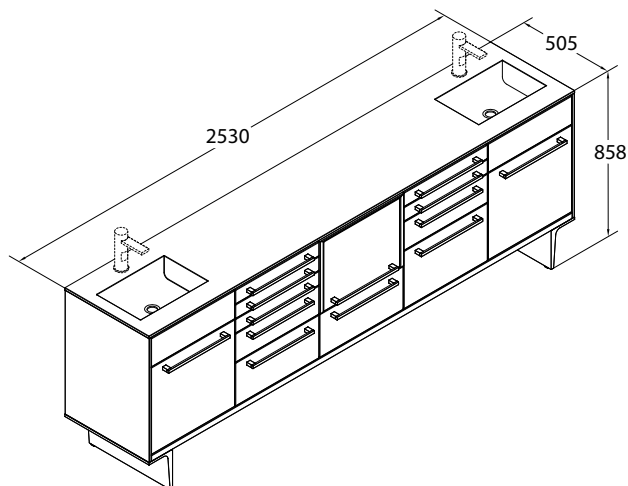

1	Piano in stratificato e fianchi verniciati Stratified top and painted sides / Plan stratifié et panneaux latéraux vernis / Arbeitsplatte aus Schichtstoff und lackierte Seitenwände / + VFA Encimera de estratificado y laterales pintados
2	Piano in vetro e fianchi verniciati Glass top and painted sides / Plan en verre et côtés peints / Arbeitsplatte aus Glas und lackierte Seitenwände / + VIV Encimera de vidrio y laterales pintados
3	Piano in Corian® e fianchi verniciati Corian® top and painted sides / Plan en Corian® et panneaux latéraux vernis / Arbeitsplatte aus Corian® und lackierte Seitenwände / + VIC Encimera de Corian® y laterales pintados
4	Piano e fianchi in Corian® Corian® top and Corian® sides / Plan et panneau latéraux en Corian® / Arbeitsplatte und Seitenwände aus Corian® / + VIC Encimera y laterales de Corian®

D **Composizione / Composition**
Composition / Zusammenstellung / Composición

VLB + V5A + VRA + V4C

La composizione è comprensiva di bacinelle standard. Rubinetto escluso.

Trays included. Mixer excluded

Intérieurs de tiroirs inclus. Robinet pas compris.

Standard Schubladeneinsätze sind enthalten. Armatur ist ausgeschlossen.

La composición incluye bandejas estándar. Grifo excluido.

E **Composizione / Composition**
Composition / Zusammenstellung / Composición

VLB + V5A + VRA + V4C + VLB

La composizione è comprensiva di bacinelle standard. Rubinetto escluso.

Trays included. Mixer excluded

Intérieurs de tiroirs inclus. Robinet pas compris.

Standard Schubladeneinsätze sind enthalten. Armatur ist ausgeschlossen.

La composición incluye bandejas estándar. Grifo excluido.

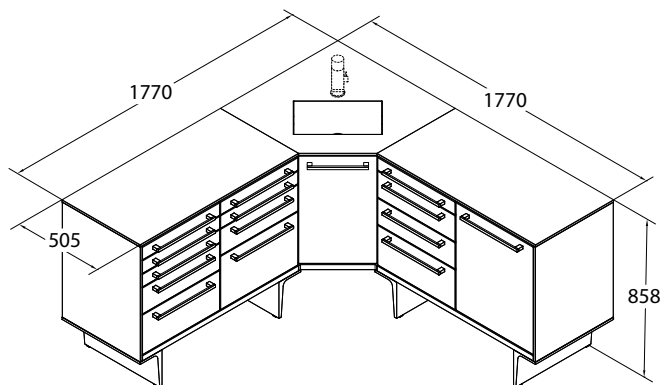

1	Piano in stratificato e fianchi verniciati Stratified top and painted sides / Plan stratifié et panneaux latéraux vernis / Arbeitsplatte aus Schichtstoff und lackierte Seitenwände / Encimera de estratificado y laterales pintados	+VFA
2	Piano in vetro e fianchi verniciati Glass top and painted sides / Plan en verre et côtés peints / Arbeitsplatte aus Glas und lackierte Seitenwände / Encimera de vidrio y laterales pintados	+VIT
3	Piano in Corian® e fianchi verniciati Corian® top and painted sides / Plan en Corian® et panneaux latéraux vernis / Arbeitsplatte aus Corian® und lackierte Seitenwände / Encimera de Corian® y laterales pintados	+VIC
4	Piano e fianchi in Corian® Corian® top and Corian® sides / Plan et panneau latéraux en Corian® / Arbeitsplatte und Seitenwände aus Corian® / Encimera y laterales de Corian®	+VIC

F **Composizione** / Composition
Composition / Zusammenstellung / Composición

V5A + V4C + VAA + V4A + VPA

La composizione è comprensiva di bacinelle standard. Rubinetto escluso.

Trays included. Mixer excluded

Intérieurs de tiroirs inclus. Robinet pas compris.

Standard Schubladeneinsätze sind enthalten. Armatur ist ausgeschlossen.

La composición incluye bandejas estándar. Grifo excluido.

Vela - Armonya - Start

Piani / Tops / Plans / Arbeitsplatten / Encimeras

Loran
everyday passion

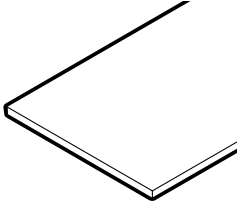
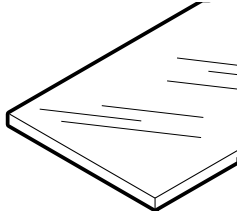
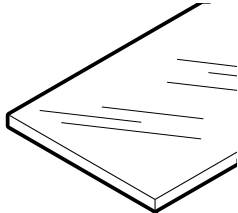
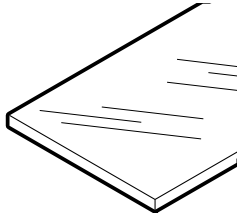
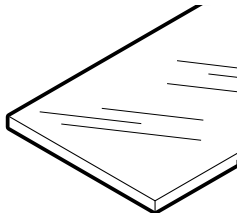
	Descrizione / Description Description / Beschreibung / Descripción	M³ Kg	Articolo Item / Article Artikel / Artículo
 <p>Piano in Corian® bianco: al metro lineare White Corian® top: per meter Plan en Corian® blanc: au mètre Weiß Corian® Arbeitsplatte: je Meter Encimera de Corian® blanco: al m.</p>		- 11	CB (P 505 mm)
	<p>P 505 x H 12 mm P 600 x H 12 mm</p>		- 13
 <p>Piano in vetro: al metro lineare Glass top: per meter Plan en verre: au mètre Glasarbeitsplatte: je Meter Encimera de vidrio: al m.</p>		- 19	VB
	<p>P 505 x H 15 mm</p>		
 <p>Piano in vetro satinato: al metro lineare Glass top satin: per meter Plan en verre dépoli: au mètre Satinierte Glasarbeitsplatte: je Meter Encimera de vidrio satinado: al m.</p>		- 19	XB
	<p>P 505 x H 15 mm</p>		
 <p>Piano in vetro extra-chiaro: al metro lineare Extra clear glass top: per meter Plan en verre transparent: au mètre Transparente Glasarbeitsplatte: je Meter Encimera de vidrio transparente: al m.</p>		- 19	YB
	<p>P 505 x H 15 mm</p>		
 <p>Piano in vetro extra-chiaro satinato: al metro lineare Extra-clear glass top satin: per meter Plan en verre transparent dépoli: au mètre Transparente satinierte Glasarbeitsplatte: je Meter Encimera de vidrio transparente satinado: al m.</p>		- 19	ZB
	<p>P 505 x H 15 mm</p>		

Vela - Armonya - Start

Piani / Tops / Plans / Arbeitsplatten / Encimeras

Loran
everyday passion

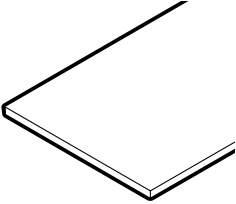
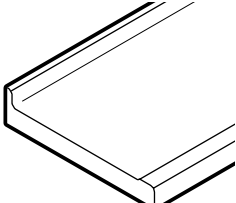
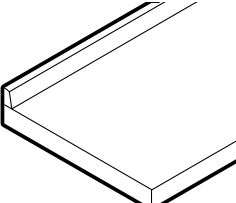
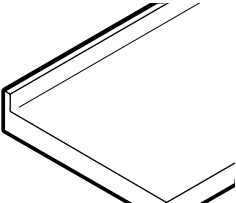
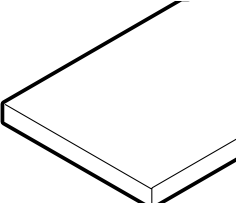
	Descrizione / Description Description / Beschreibung / Descripción	M³ Kg	Articolo Item / Article Artikel / Artículo
 <p>Piano in stratificato bianco: al metro lineare White stratified top: per meter Plan en stratifié blanc: au mètre Weiß Schichtstoffarbeitsplatte: je Meter Encimera de estratificado blanco: al m.</p> <p>P 505 x H 12 mm P 600 x H 12 mm</p>		- 9,6	SB (P 505 mm)
		- 11,4	SD (P 600 mm)
 <p>Piano in laminato con alzatina incorporata H 45 mm: al metro lineare Laminated top with rear trim H 45 mm: per meter Plan en laminé avec dossier H 45 mm: au mètre Laminatarbeitsplatte mit Aufkantung H 45 mm: je Meter Encimera de laminado con elevación H 45 mm: al m.</p> <p>P 460 x H 30 mm P 520 x H 30 mm</p>		- 10	BA (P 460 mm)
		- 11	BC (P 520 mm)
 <p>Piano in laminato con alzatina applicata ALB H 40 mm: al metro lineare Laminated top with applied rear trim ALB H 40 mm: per meter Plan en laminé avec dossier appliqué ALB H 40 mm: au mètre Laminatarbeitsplatte mit aufgeklebter Aufkantung ALB H 40 mm: je Meter Encimera de laminado con elevación aplicado ALB H 40 mm: al m.</p> <p>P 460 x H 30 mm P 520 x H 30 mm P 600 x H 30 mm</p>		- 10	TA (P 460 mm)
		- 11	TC (P 520 mm)
		- 12	TD (P 600 mm)
 <p>Piano in acciaio inox con alzatina incorporata H 70 mm: al metro lineare Stainless steel top with rear trim H 70 mm: per meter Plan en acier inox avec dossier H 70 mm: au mètre Edelstahlarbeitsplatte mit Aufkantung H 70 mm: je Meter Encimera de acero inox con elevación H 70 mm: al m.</p> <p>P 520 x H 30 mm P 600 x H 30 mm</p>		- 14	HC (P 520 mm)
		- 18	HD (P 600 mm)
 <p>Piano in acciaio inox senza alzatina: al metro lineare Stainless steel top: per meter Plan en acier inox : au mètre Edelstahlarbeitsplatte: je Meter Encimera de acero inox: al m.</p> <p>P 520 x H 30 mm P 600 x H 30 mm</p>		- 13	IC (P 520 mm)
		- 15	ID (P 600 mm)

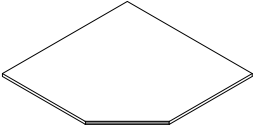
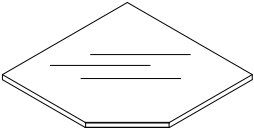
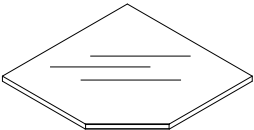
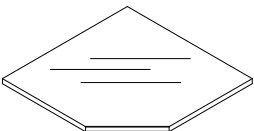
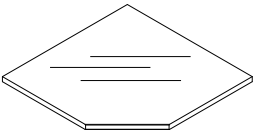
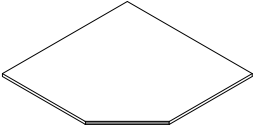
	Descrizione / Description Description / Beschreibung / Descripción	M³ Kg	Articolo Item / Article Artikel / Artículo
	<p>Piano angolare in Corian® bianco</p> <p>White Corian® top for corner units Plan en Corian® blanc pour modules d'angle Weiß Corian® Arbeitsplatte für Eckschränke Encimera de Corian® blanco para módulos angulares</p>	- 11,6	CBV
L 755 x P 755 x H 12 mm			
	<p>Piano angolare in vetro</p> <p>Glass top for corner units Plan en verre pour modules d'angle Glasarbeitsplatte für Eckschränke Encimera de vidrio para módulos angulares</p>	- 20,2	VBV
L 755 x P 755 x H 15 mm			
	<p>Piano angolare in vetro satinato</p> <p>Glass top satin for corner units Plan en verre dépoli pour modules d'angle Satinierte Glasarbeitsplatte für Eckschränke Encimera de vidrio satinado para módulos angulares</p>	- 20,2	XBV
L 755 x P 755 x H 15 mm			
	<p>Piano angolare in vetro extra-chiaro</p> <p>Extra-clear glass top for corner units Plan en verre transparent pour modules d'angles Transparente Glasarbeitsplatte für Eckschränke Encimera de vidrio transparente para módulos angulares</p>	- 20,2	YBV
L 755 x P 755 x H 15 mm			
	<p>Piano angolare in vetro extra-chiaro satinato</p> <p>Extra clear glass top satin for corner units Plan en verre transparent dépoli pour modules d'angles Transparente satinierte Glasarbeitsplatte für Eckschränke Encimera de vidrio trasparente satinado para módulos angulares</p>	- 20,2	ZBV
L 755 x P 755 x H 15 mm			
	<p>Piano angolare in stratificato bianco</p> <p>White stratified top for corner units Plan en stratifié blanc pour modules d'angles Weiß Schichtstoffarbeitsplatte für Eckschränke Encimera de estratificado blanco para módulos angulares</p>	- 10,2	SBV
L 755 x P 755 x H 12 mm			

Vela - Armonya - Start

Alzatine / Splashbacks / Dosserets / Aufkantungen / Alzadas

Loran
everyday passion

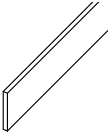
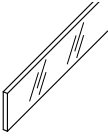
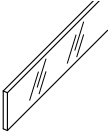
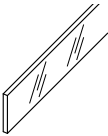
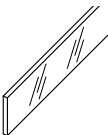
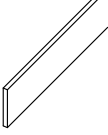
	Descrizione / Description Description / Beschreibung / Descripción	M³ Kg	Articolo Item / Article Artikel / Artículo
 SP 12 x H 80 mm SP 12 x H 12 mm	Alzatina in Corian® bianco: al metro lineare White Corian® splashback: per meter Dosseret en Corian® blanc: au mètre Weiß Corian® Aufkantung: je Meter Alzada de Corian® blanco: al m.	- 1,5	AC08 (H 80 mm)
		- 0,3	AC01 (H 12 mm)
 SP 15 x H 80 mm SP 15 x H 100 mm	Alzatina in vetro: al metro lineare Glass splashback: per meter Dosseret en verre: au mètre Glasaufkantung: je Meter Alzada de vidrio: al m.	- 3	AV08 (H 80 mm)
		- 3,8	AV10 (H 100 mm)
 SP 15 x H 80 mm SP 15 x H 100 mm	Alzatina in vetro satinato: al metro lineare Glass splashback satin: per meter Dosseret en verre dépoli: au mètre Satinierte Glasaufkantung: je Meter Alzada de vidrio satinado: al m.	- 3	AX08 (H 80 mm)
		- 3,8	AX10 (H 100 mm)
 SP 15 x H 80 mm SP 15 x H 100 mm	Alzatina in vetro extra-chiaro: al metro lineare Extra-clear glass splashback: per meter Dosseret en verre transparent: au mètre Transparente Glasaufkantung: e Meter Alzada de vidrio transparente: al m.	- 3	AY08 (H 80 mm)
		- 3,8	AY10 (H 100 mm)
 SP 15 x H 80 mm SP 15 x H 100 mm	Alzatina in vetro extra-chiaro satinato: al metro lineare Extra-clear glass splashback satin: per meter Dosseret en verre transparent dépoli: au mètre Transparente satinierte Glasaufkantung: e Meter Alzada de vidrio transparente satinado: al m.	- 3	AZ08 (H 80 mm)
		- 3,8	AZ10 (H 100 mm)
 SP 12 x H 80 mm SP 12 x H 100 mm	Alzatina in stratificato bianco: al metro lineare White stratified splashback: per meter Dosseret en stratifié blanc: au mètre Weiß Schichtstoffaufkantung: je Meter Alzada de estratificado blanco: al m.	- 1,5	AS08 (H 80 mm)
		- 1,8	AS10 (H 100 mm)

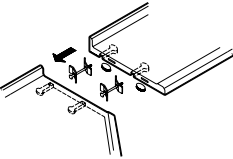
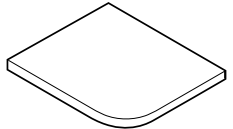
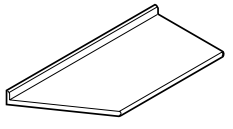
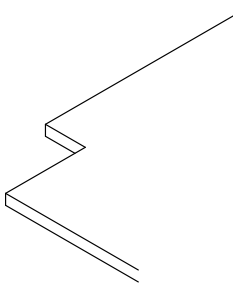
	Descrizione / Description Description / Beschreibung / Descripción	M³ Kg	Articolo Item / Article Artikel / Artículo										
	Set collegamento 2 piani laminato Worktop-connection set Set pour la liaison de 2 plans de travail Set für Zusammenbau von Arbeitsplatten Juego para la unión de las 2 encimeras		SCP										
	Arrotondamento spigolo del piano Corner-rounding for top Angle arrondi pour le plan de travail Abgerundete Kanten der Arbeitsplatte Angulo redondeado de la encimera		<table border="1"> <tr> <td>Corian®</td> <td>ARC</td> </tr> <tr> <td>Vetro / Glass / Verre / Glas / Vidrio</td> <td>ARV</td> </tr> <tr> <td>Stratificato / Stratified / Stratifié / Schichtstoff / Estratificado</td> <td>ARS</td> </tr> <tr> <td>Laminato / Laminate / Laminé / Laminat / Laminado</td> <td>ARP</td> </tr> <tr> <td>Acciaio inox / Stainless steel / Acier Inox / Edelstahl / Acero inoxidable</td> <td>ARI</td> </tr> </table>	Corian®	ARC	Vetro / Glass / Verre / Glas / Vidrio	ARV	Stratificato / Stratified / Stratifié / Schichtstoff / Estratificado	ARS	Laminato / Laminate / Laminé / Laminat / Laminado	ARP	Acciaio inox / Stainless steel / Acier Inox / Edelstahl / Acero inoxidable	ARI
Corian®	ARC												
Vetro / Glass / Verre / Glas / Vidrio	ARV												
Stratificato / Stratified / Stratifié / Schichtstoff / Estratificado	ARS												
Laminato / Laminate / Laminé / Laminat / Laminado	ARP												
Acciaio inox / Stainless steel / Acier Inox / Edelstahl / Acero inoxidable	ARI												
	Taglio obliquo su piano Special cut of top Découpe spéciale sur le plan de travail Sonderschnitt der Arbeitsplatte Corte especial sobre la encimera		<table border="1"> <tr> <td>Corian®</td> <td>TSC</td> </tr> <tr> <td>Vetro / Glass / Verre / Glas / Vidrio</td> <td>TSV</td> </tr> <tr> <td>Stratificato / Stratified / Stratifié / Schichtstoff / Estratificado</td> <td>TSS</td> </tr> <tr> <td>Laminato / Laminate / Laminé / Laminat / Laminado</td> <td>TSP</td> </tr> <tr> <td>Acciaio inox / Stainless steel / Acier Inox / Edelstahl / Acero inoxidable</td> <td>TSI</td> </tr> </table>	Corian®	TSC	Vetro / Glass / Verre / Glas / Vidrio	TSV	Stratificato / Stratified / Stratifié / Schichtstoff / Estratificado	TSS	Laminato / Laminate / Laminé / Laminat / Laminado	TSP	Acciaio inox / Stainless steel / Acier Inox / Edelstahl / Acero inoxidable	TSI
Corian®	TSC												
Vetro / Glass / Verre / Glas / Vidrio	TSV												
Stratificato / Stratified / Stratifié / Schichtstoff / Estratificado	TSS												
Laminato / Laminate / Laminé / Laminat / Laminado	TSP												
Acciaio inox / Stainless steel / Acier Inox / Edelstahl / Acero inoxidable	TSI												
	Taglio a "L" su piano Special cut of top Découpe spéciale sur le plan de travail Sonderschnitt der Arbeitsplatte Corte especial sobre la encimera		<table border="1"> <tr> <td>Corian®</td> <td>T1C</td> </tr> <tr> <td>Vetro / Glass / Verre / Glas / Vidrio</td> <td>T1V</td> </tr> <tr> <td>Stratificato / Stratified / Stratifié / Schichtstoff / Estratificado</td> <td>T1S</td> </tr> <tr> <td>Laminato / Laminate / Laminé / Laminat / Laminado</td> <td>T1P</td> </tr> <tr> <td>Acciaio inox / Stainless steel / Acier Inox / Edelstahl / Acero inoxidable</td> <td>T1I</td> </tr> </table>	Corian®	T1C	Vetro / Glass / Verre / Glas / Vidrio	T1V	Stratificato / Stratified / Stratifié / Schichtstoff / Estratificado	T1S	Laminato / Laminate / Laminé / Laminat / Laminado	T1P	Acciaio inox / Stainless steel / Acier Inox / Edelstahl / Acero inoxidable	T1I
Corian®	T1C												
Vetro / Glass / Verre / Glas / Vidrio	T1V												
Stratificato / Stratified / Stratifié / Schichtstoff / Estratificado	T1S												
Laminato / Laminate / Laminé / Laminat / Laminado	T1P												
Acciaio inox / Stainless steel / Acier Inox / Edelstahl / Acero inoxidable	T1I												

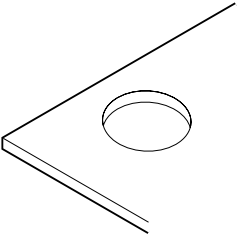
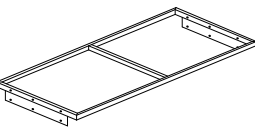
	Descrizione / Description Description / Beschreibung / Descripción	M³ Kg	Articolo Item / Article Artikel / Artículo
	<p>Foro Ø 150 mm su piano, per rifiuti Waste hole Ø 150 mm for top Trou passage déchets Ø 150 mm, pour plan Abfallloch Ø 150 mm für Arbeitsplatte Agujero Ø 150 mm para la basura, sobre encimera</p>		
	<p>Corian®</p>		FRC
	<p>Vetro / Glass / Verre / Glas / Vidrio</p>		FRV
	<p>Stratificato / Stratified / Stratifié / Schichtstoff / Estratificado</p>		FRS
	<p>Laminato / Laminare / Laminé / Laminat / Laminado</p>		FRT
	<p>Telaio supporto piano a sbalzo per piani Corian®, vetro, stratificato: al metro lineare Frame to support the top in Corian®, glass, stratified Châssis pour soutenir le plan en Corian®, verre, stratifié Rahmen für Arbeitsplatte aus Corian®, Glas, Schichtstoff Frame para apoyar las encimeras de Corian®, vidrio, estratificado</p>		STS

Vela - Armonya - Start

Lavelli / Sinks / Evers / Waschbecken / Lavabos

Loran
everyday passion

Descrizione / Description
Description / Beschreibung / Descripción

M³
Kg

Articolo
Item / Article
Artikel / Artículo

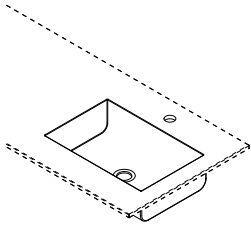

Lavello integrato in Corian®

Integrated Corian® sink
Evier intégré en Corian®
Integrierte Waschbecken aus Corian®
Lavabo integrado de Corian®

L 400 x P 260 x H 110 mm

VIC

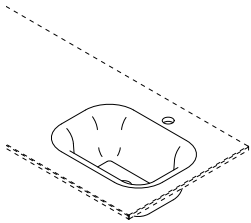

Lavello termoformato in Corian®

Integrated thermoformed Corian® sink
Evier intégré thermoformé en Corian®
Integriertes tiefgezogenes Waschbecken aus Corian®
Lavabo integrado termoformato de Corian®

L 400 x P 300 x H 130 mm

VTC

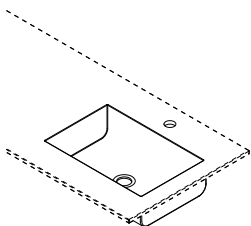

Lavello sottopiano in acciaio inox, per piani in Corian® e stratificato

Undermont stainless steel sink, for Corian® and stratified top
Evier en inox, pour plans en Corian® et stratifié
Unterbauedelstahlwaschbecken, für Arbeitsplatte aus Corian®
und Schichtstoff
Lavabo bajo encimera de acero para encimeras de
Corian® y estratificado

L 400 x P 270 x H 195 mm

VFA

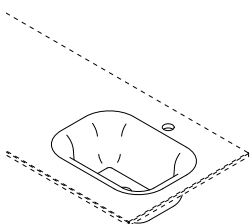

Lavello integrato in vetro

Integrated glass sink
Evier intégré en verre
Integriertes, tiefgezogenes Glaswaschbecken
Lavabo integrado de vidrio

NB: piani lineari L 2800 mm max. / Straight tops L 2800 mm max. /
Plans linéaires L 2800 mm max. / Gerade Arbeitsplatte L 2800 mm max. /
Encimera lineal L 2800 mm max.

L 400 x P 300 x H 130 mm

VIV

Vela - Armonya - Start

Lavelli / Sinks / Evers / Waschbecken / Lavabos

Loran
everyday passion

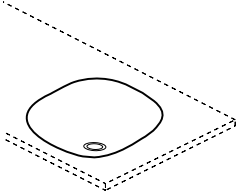
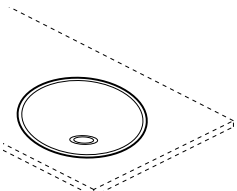
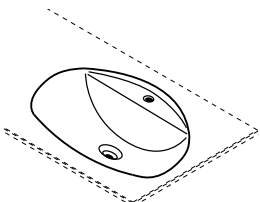
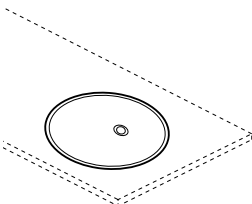
	Descrizione / Description Description / Beschreibung / Descripción	M³ Kg	Articolo Item / Article Artikel / Artículo
	<p>Lavello integrato in vetro (NO satinato / NO angolare) Integrated glass sink (NOT satin / NOT corner) Evier intégré en verre (PAS dépoli / PAS d'angle) Integrierte Glaswaschbecken (NICHT satiniert / NICHT Ecke) Lavabo integrado de vidrio (NO satinado / NO angular)</p> <p>NB: piani lineari L 2100 mm max. (solo all'estremità sx o dx del piano) / Straight tops L 2100 mm max. (only at the right or left end of the top) Plans linéaires L 2100 mm max. (uniquement à l'extrémité gauche ou droite du plan) Gerade Arbeitsplatte L 2100 mm max. (nur am linken oder rechten Ende der Arbeitsplatte) Encimera lineal L 2100 mm max. (sólo en el extremo izdo. o dcho. de la encimera)</p>		
L 320 x P 320 mm			VI
	<p>Lavello a semisfera in acciaio inox sopra piano Top mounted stainless steel sink Evier en inox sur plan Aufgesetztes Edelstahlwaschbecken Lavabo de acero sobre encimera</p> <p>NB: si consiglia il rubinetto RB3 / mixer RB3 suggested / robinet RB3 conseillé / Wasserhahn RB3 empfohlen / se aconseja el grifo RB3</p>		
Ø 340 mm - H 160 mm		$\frac{-}{1}$	VAS
	<p>Lavello in ceramica a filo piano Flush ceramic bowl Evier porcelaine collée sous le plan Porzellanwaschbecken bündig mit der Arbeitsplatte Lavabo de cerámica a ras de la encimera</p>		
	Laminato / Laminato / Laminé / Laminat / Laminado	$\frac{-}{7,2}$	VCF
L 455 x P 405 mm	Stratificato / Stratified / Stratifié / Schichtstoff / Estratificado	$\frac{-}{7,2}$	VCS
	<p>Lavello in acciaio smaltato Enamel steel sink Evier en acier inox émaillé Aufgesetztes emailiertes Stahl-Waschbecken Lavabo de acero esmaltado</p>		
Ø 340 mm - H 160 mm		$\frac{-}{1}$	VSS

Vela - Armonya - Start

Rubinetti / Mixers / Robinets / Wasserhähne / Grifos

Loran
everyday passion

Descrizione / Description
Description / Beschreibung / Descripción

M³
Kg

Articolo
Item / Article
Artikel / Artículo

Per lo STUDIO / For DENTAL OFFICE /- Pour le CABINET / Für PRAXIS / Por el ESTUDIO

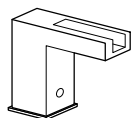

Rubinetto "a cascata" con fotocellula

Mixer "a cascata" with photoelectric cell
Robinet électronique "a cascata" à photocellule
Elektronische Wasserhahn "a cascata" mit Fotozelle
Grifo "a cascata" con fotocélula

-
4

RB8

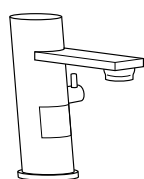

Rubinetto con fotocellula

Mixer with photoelectric cell
Robinet électronique à photocellule
Elektronische Wasserhahn mit Fotozelle
Grifo con fotocélula

-
3

RB7

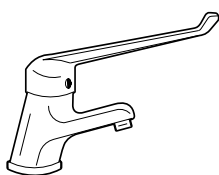

Rubinetto cromato a leva lunga

Chromed mixer with long lever
Robinet chromé à levier long
Verchromte Wasserhahn mit langem Hebel
Grifo cromado con palanca larga

-
1,5

RB2

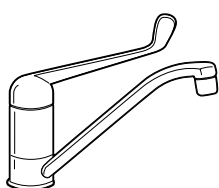

Rubinetto cromato con collo lungo e leva lunga

Chromed mixer with long neck and long lever
Robinet chromé à col long et levier long
Verchromte Langrohrgrohn- und Langhebel-Wasserhahn
Grifo cromado con caño largo y palanca larga

-
1,5

RB3

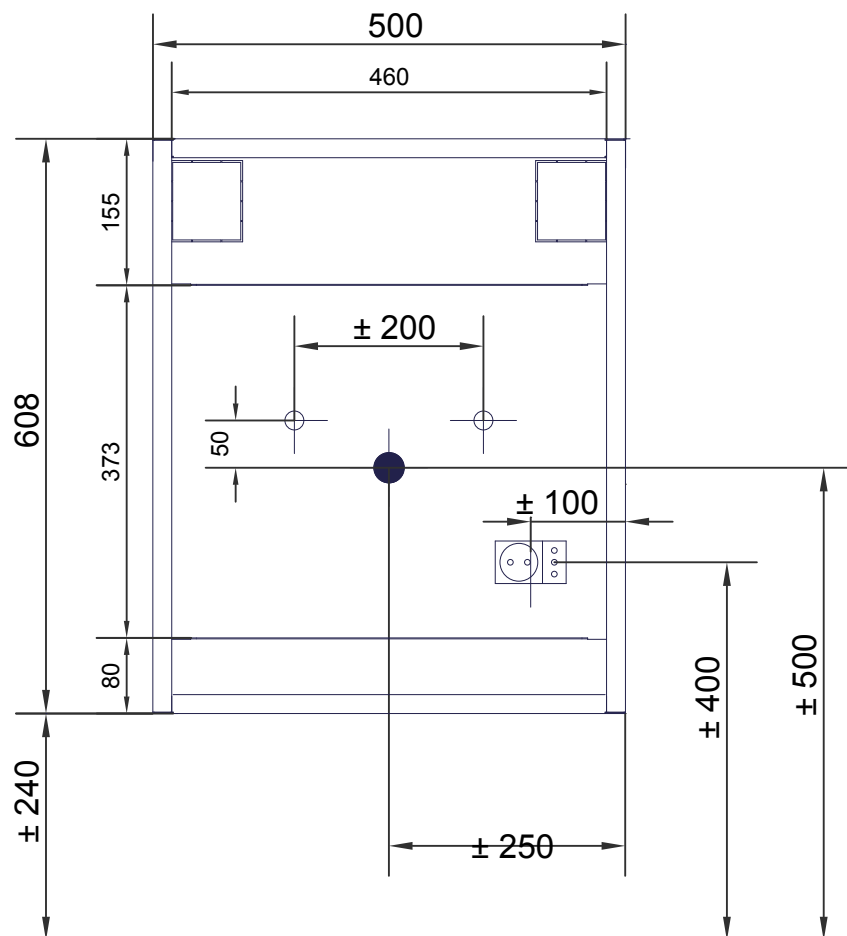

Colori

Colors / Couleurs / Farben / Colores

Loran
everyday passion

Finiture verniciate / Painted finishes / Finitions peintes / Lackierten Ausführungen / Acabados pintados

BIANCO	RAL 1015	RAL 1018	RAL 1023	RAL 2001	RAL 2012	RAL3000
RAL 3004	RAL 3016	RAL 4002	RAL 4006	RAL 5000	RAL 5002	RAL 5010
RAL 5012	RAL 5014	RAL 5022	RAL 5024	RAL 6000	RAL 6019	RAL 6027
RAL 7016	RAL 7022	RAL 7038	RAL 7045	RAL 8019	RAL 9001	RAL 9002
RAL 9005	SILVER	APRICOT	602 PLA	C3526	GLICINE	SILBER METALLIC

Colorazioni speciali con maggiorazione di prezzo / Special colors with upcharge / Couleurs spéciales avec supplément de prix / Sonderfarben gegen einem Aufpreis / Coloraciones especiales disponibles por un cargo adicional

Colori piani in vetro / Colors of the glass tops / Couleurs des plans en verre / Farben der Glasarbeitsplatten / Colores de las encimeras de vidrio

Vetro extra-chiaro / Extra clear glass / Verre transparent / Transparent Glas / Vidrio transparente

TURCHESE	LIMONE	VERDE ACQUA	VERDE	GIALLO	AZZURRO MEDITERRANEO	GLICINE
CELESTE	BLU CINA	ROSSO GRANATA	ROSSO VENEZIANO	SALMONE	GIALLO NEVADA	BIANCO

Questo campionario deve essere considerato solo come guida indicativa del colore e non può essere utilizzato come riferimento originale per la produzione e la valutazione di superfici colorate.

This sample should only be considered as an indicative colour guide and cannot be used as an original reference for the production and assessment of colored surfaces.

Ce nuancier ne sert qu'à donner une idée des différents coloris et ne doit en aucun cas être utilisé comme référence originale pour la production et l'évaluation des surfaces colorées.

Diese Farbmuster sind unverbindlich und können vom Original Farbton der hergestellten Oberflächen abweichen.

Esta muestra de colores debe considerarse sólo como una guía indicativa del color, y no puede utilizarse como referencia original para la producción y evaluación de las superficies pintadas.

Descrizione / Description Description / Beschreibung / Descripción	M ³ Kg	Articolo Item / Article Artikel / Artículo
---	----------------------	--



L 1030 x P 200 x H 400 mm

PENSILE CON ANTA A RIBALTA VERNICIATA

Wall unit with painted pull-up door / Élément mural avec porte vernie avec ouverture vers le haut / Hängeschrank mit lackierten Tür mit Öffnung nach oben / Mueble colgante con puerta pintada con apertura hacia arriba

0,15
32

ALA10

PENSILE CON ANTA A RIBALTA IN VETRO

Wall unit with glass pull-up door / Élément mural avec porte en verre avec ouverture vers le haut / Hängeschrank mit Glastür mit Öffnung nach oben / Mueble colgante con puerta de vidrio con apertura hacia arriba

0,15
30

ALA10V

PENSILE CON ANTA A RIBALTA A SPECCHIO

Wall units with mirror pull-up door / Élément mural avec porte avec miroir avec ouverture vers le haut / Hängeschrank mit Spiegeltür mit Öffnung nach oben / Mueble colgante con puerta con espejo con apertura hacia arriba

0,15
30

ALA10S

Completo di:

n. 1 distributore di bicchieri; n. 1 distributore di sapone automatico con fotocellula;
 n. 2 alloggiamenti per guanti o salviette; n. 1 alloggiamento per mascherine;
 n. 2 portarotolo per carta e mantelline.

Complete of:

n. 1 glass dispenser; n. 1 photocell-controlled soap dispenser;
 n. 2 spaces for gloves and serviettes; n. 1 place for face masks;
 n. 2 paper roll and cape carriers.

Composé de:

n. 1 distributeur de gobelets; n. 1 distributeur de savon automatique avec cellule photoélectrique;
 n. 2 logements pour gants ou serviettes; n. 1 logement pour masques;
 n. 2 supports de rouleau pour papier et capes.

Komplett mit:

n. 1 Verteiler von Bechern; n. 1 automatischer Seifenspender mit Lichtschranke;
 n. 2 Platz für Handschuhe oder Servietten; n. 1 Steckplatz für Maskern;
 n. 2 Papierrollenträger und Schulterumhänge.

Dotado de:

n. 1 dispensador de vasos; n. 1 dispensador de jabón automático con fotocélula;
 n. 2 alojamiento para guantes servilletas; n. 1 alojamiento para mascarillas; n. 1 alojamiento para mordazas y/o cánulas; n. 2 porta rollo para papel y capas.

Descrizione / Description Description / Beschreibung / Descripción	M ³ Kg	Articolo Item / Article Artikel / Artículo
---	----------------------	--



L 1530 x P 200 x H 400 mm

PENSILE CON ANTA A RIBALTA VERNICIATA

Wall unit with painted pull-up door / Élément mural avec porte vernie avec ouverture vers le haut / Hängeschrank mit lackierten Tür mit Öffnung nach oben / Mueble colgante con puerta pintada con apertura hacia arriba

0,22
51

ALA15

PENSILE CON ANTA A RIBALTA IN VETRO

Wall unit with glass pull-up door / Élément mural avec porte en verre avec ouverture vers le haut / Hängeschrank mit Glastür mit Öffnung nach oben / Mueble colgante con puerta de vidrio con apertura hacia arriba

0,22
49

ALA15V

PENSILE CON ANTA A RIBALTA A SPECCHIO

Wall units with mirror pull-up door / Élément mural avec porte avec miroir avec ouverture vers le haut / Hängeschrank mit Spiegeltür mit Öffnung nach oben / Mueble colgante con puerta con espejo con apertura hacia arriba

0,22
49

ALA15S

Completo di:

n. 1 distributore di bicchieri; n. 1 distributore di sapone automatico con fotocellula;
n. 3 alloggiamenti per guanti o salviette; n. 1 alloggiamento per mascherine;
n. 1 alloggiamento per bavagli o canule; n. 2 portarotolo per carta e mantelline.

Complete of:

n. 1 glass dispenser; n. 1 photocell-controlled soap dispenser;
n. 3 spaces for gloves and serviettes; n. 1 place for face masks;
n. 1 place for bibs and cannulas; n. 2 paper roll and cape carriers.

Composé de:

n. 1 distributeur de gobelets; n. 1 distributeur de savon automatique avec cellule photoélectrique; n. 3 logements pour gants ou serviettes; n. 1 logement pour masques;
n. 1 logement pour bavoires ou canules; n. 2 supports de rouleau pour papier et capes.

Komplett mit:

n. 1 Verteiler von Bechern; n. 1 automatischer Seifenspender mit Lichtschranke;
n. 3 Platz für Handschuhe oder Servietten; n. 1 Steckplatz für Masken;
n. 1 Steckplatz für Lätzchen oder Kanülen; n. 2 Papierrollenträger und Schulterumhänge.

Dotado de:

n. 1 dispensador de vasos; n. 1 dispensador de servilletas; n. 1 dispensador de jabón automático con fotocélula; n. 3 alojamientos para guantes o servilletas;
n. 1 alojamiento para mascarillas; n. 1 alojamiento para mordazas o cánulas; n. 2 porta rollo para papel y capas.

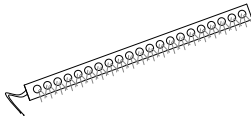
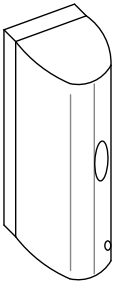
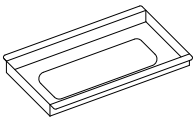
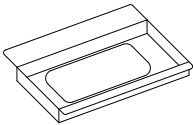
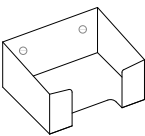
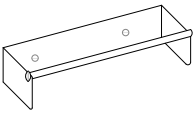
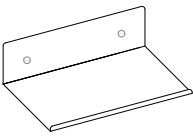
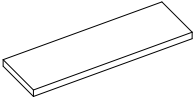

	Descrizione / Description Description / Beschreibung / Descripción	Dim. Dim. / Dim. Maß / Dim. mm	M³ Kg	Articolo Item / Article Artikel / Artículo
	LAMPADA A LED LED lamp Lampe àLEDs LED-Leuchte Lámpara de LED	L = 1030		LED10
		L = 1530		LED15
	DISTRIBUTORE DI SAPONE AUTOMATICO con fotocellula Photocell-controlled SOAP DISPENSER DISTRIBUTEUR DE SAVON AUTOMATIQUE avec cellule photoélectrique AUTOMATISCHER SEIFENSPENDER mit Fotozelle DISPENSADOR DE JABÓN AUTOMÁTICO con fotocélula		- 1,2	DSF
	ALLOGGIAMENTO per guanti o salviette SPACE for gloves and serviettes LOGEMENT pour gants ou serviettes STECKPLATZ für Handschuhe oder Tücher ALOJAMIENTO para guantes o servilletas	L 240 x P 130	- 0,6	ALAPG
	ALLOGGIAMENTO per mascherine PLACE for face masks LOGEMENT pour masques STECKPLATZ für Masken ALOJAMIENTO para mascarillas	L 185 x P 105	- 0,5	ALAPM
	ALLOGGIAMENTO per bavagli o canule PALCE for bibs and cannulas LOGEMENT pour bavoires ou canules STECKPLATZ für Lätzchen oder Kanülen ALOJAMIENTO para mordazas o cánulas	L 185 x P 125	- 0,9	ALAPT
	PORTAROTOLO per carta o mantelline Paper roll and cape CARRIER SUPPORT DE ROULEAU pour papier et capes PAPIERROLLENTÄGER und Schulterumhänge PORTA ROLLO para papel y capas	L 322	- 0,7	ALAPR
	MENSOLA Shelf Etagère Regal Repisa	L 250	-0,8	ALAME25
		L 500	-1,6	ALAME50
		L 1000		ALAME100
		L 1500		ALAME150
	FONDO Bottom Fond Unterseite Parte inferior	L 1030	-0,8	ALAFO100
		L 1530	-1,6	ALAFO150

Colori

Colors / Couleurs / Farben / Colores

Loran
everyday passion

Finiture verniciate / Painted finishes / Finitions peintes / Lackierten Ausführungen / Acabados pintados

						
BIANCO	RAL 1015	RAL 1018	RAL 1023	RAL 2001	RAL 2012	RAL3000
						
RAL 3004	RAL 3016	RAL 4002	RAL 4006	RAL 5000	RAL 5002	RAL 5010
						
RAL 5012	RAL 5014	RAL 5022	RAL 5024	RAL 6000	RAL 6019	RAL 6027
						
RAL 7016	RAL 7022	RAL 7038	RAL 7045	RAL 8019	RAL 9001	RAL 9002
						
RAL 9005	SILVER	APRICOT	602 PLA	C3526	GLICINE	SILBER METALLIC

Colorazioni speciali con maggiorazione di prezzo / Special colors with upcharge / Couleurs spéciales avec supplément de prix / Sonderfarben gegen einem Aufpreis / Coloraciones especiales disponibles por un cargo adicional

Colori piani in vetro / Colors of the glass tops / Couleurs des plans en verre / Farben der Glasarbeitsplatten / Colores de las encimeras de vidrio

Vetro extra-chiaro / Extra clear glass / Verre transparent / Transparent Glas / Vidrio transparente

						
TURCHESE	LIMONE	VERDE ACQUA	VERDE	GIALLLO	AZZURRO MEDITERRANEO	GLICINE
						
CELESTE	BLU CINA	ROSSO GRANATA	ROSSO VENEZIANO	SALMONE	GIALLLO NEVADA	BIANCO





Questo campionario deve essere considerato solo come guida indicativa del colore e non può essere utilizzato come riferimento originale per la produzione e la valutazione di superfici colorate.

This sample should only be considered as an indicative colour guide and cannot be used as an original reference for the production and assessment of colored surfaces.

Ce nuancier ne sert qu'à donner une idée des différents coloris et ne doit en aucun cas être utilisé comme référence originale pour la production et l'évaluation des surfaces colorées.

Diese Farbmuster sind unverbindlich und können vom Original Farbton der hergestellten Oberflächen abweichen.

Esta muestra de colores debe considerarse sólo como una guía indicativa del color, y no puede utilizarse como referencia original para la producción y evaluación de las superficies pintadas.

	Descrizione / Description Description / Beschreibung / Descripción	M³ Kg	Articolo Item / Article Artikel / Artículo
 <p>L 430 x P 500 x H 845 mm</p>	<p>CARRELLO PORTA APPARECCHI con prese multiple EQUIPMENT-CARRYING TROLLEY with multiple power sockets CARIOT POUR APPAREILS avec prises multiples Gerätetragewagen (Trolley für Geräte) mit Steckdosenleisten CARRO PORTA EQUIPOS con tomas múltiples</p>	<p>0,22 23</p>	<p>LUNA</p>
 <p>L 430 x P 500 x H 845 mm</p>	<p>CARRELLO PORTA APPARECCHI con prese multiple e PANNELLI COLORATI* EQUIPMENT-CARRYING TROLLEY with multiple power sockets AND COLOURED PANELS* CARIOT POUR APPAREILS avec prises multiples ET PANNEAUX EN COULEUR* Gerätetragewagen (Trolley für Geräte) mit Steckdosenleisten und farbige Paneele* CARRO PORTA EQUIPOS con tomas múltiples y PANELES DE COLORES*</p> <p>* Tinte RAL / RAL colors / couleurs RAL / RAL Farbe / colores RAL</p>	<p>0,22 23</p>	<p>LUNAV</p>
 <p>L 430 x P 500 x H 845 mm</p>	<p>CARRELLO PORTA APPARECCHI con cassetto e prese multiple EQUIPMENT-CARRYING TROLLEY with drawer and multiple power sockets CARIOT POUR APPAREILS avec tiroir et prises multiples Gerätetragewagen (Trolley für Geräte) mit Schublade und Steckdosenleisten CARRO PORTA EQUIPOS con cajones y tomas múltiples</p>	<p>0,22 2,6</p>	<p>LUNAC</p>
 <p>L 430 x P 500 x H 845 mm</p>	<p>CARRELLO PORTA APPARECCHI con cassetto e prese multiple e PANNELLI COLORATI* EQUIPMENT-CARRYING TROLLEY with drawer, multiple power sockets AND COLOURED PANELS* CARIOT POUR APPAREILS avec tiroir, avec prises multiples ET PANNEAUX EN COULEUR* Gerätetragewagen (Trolley für Geräte) mit Schublade, Steckdosenleisten und farbige Paneele* CARRO PORTA EQUIPOS con cajón, tomas múltiples y PANELES DE COLORES*</p> <p>* Tinte RAL / RAL colors / couleurs RAL / RAL Farbe / colores RAL</p>	<p>0,22 26</p>	<p>LUNACV</p>

Colori

Colors / Couleurs / Farben / Colores

Loran
everyday passion

Finiture verniciate / Painted finishes / Finitions peintes / Lackierten Ausführungen / Acabados pintados

BIANCO	RAL 1015	RAL 1018	RAL 1023	RAL 2001	RAL 2012	RAL3000
RAL 3004	RAL 3016	RAL 4002	RAL 4006	RAL 5000	RAL 5002	RAL 5010
RAL 5012	RAL 5014	RAL 5022	RAL 5024	RAL 6000	RAL 6019	RAL 6027
RAL 7016	RAL 7022	RAL 7038	RAL 7045	RAL 8019	RAL 9001	RAL 9002
RAL 9005	SILVER	APRICOT	602 PLA	C3526	GLICINE	SILBER METALLIC

Colorazioni speciali con maggiorazione di prezzo / Special colors with upcharge / Couleurs spéciales avec supplément de prix / Sonderfarben gegen einem Aufpreis / Coloraciones especiales disponibles por un cargo adicional

Colori piani in vetro / Colors of the glass tops / Couleurs des plans en verre / Farben der Glasarbeitsplatten / Colores de las encimeras de vidrio

Vetro extra-chiaro / Extra clear glass / Verre transparent / Transparent Glas / Vidrio transparente

TURCHESE	LIMONE	VERDE ACQUA	VERDE	GIALLO	AZZURRO MEDITERRANEO	GLICINE
CELESTE	BLU CINA	ROSSO GRANATA	ROSSO VENEZIANO	SALMONE	GIALLO NEVADA	BIANCO

Questo campionario deve essere considerato solo come guida indicativa del colore e non può essere utilizzato come riferimento originale per la produzione e la valutazione di superfici colorate.

This sample should only be considered as an indicative colour guide and cannot be used as an original reference for the production and assessment of colored surfaces.

Ce nuancier ne sert qu'à donner une idée des différents coloris et ne doit en aucun cas être utilisé comme référence originale pour la production et l'évaluation des surfaces colorées.

Diese Farbmuster sind unverbindlich und können vom Original Farbton der hergestellten Oberflächen abweichen.

Esta muestra de colores debe considerarse sólo como una guía indicativa del color, y no puede utilizarse como referencia original para la producción y evaluación de las superficies pintadas.